

TRAFFIC



WIŚNIOWSKI

GATES | WINDOWS | DOORS | FENCES

TRAFFIC INDUSTRIAL FOLDING GATE

Intended use: The **Traffic** gate is a perfect solution for areas where the speed of operation and the number of daily opening cycles are of crucial importance. The gate combines the advantages of a double-leaf gate and a barrier, enabling permanent access control or traffic control.



SOLID

The gate is supported on posts using a special system of hinges and linkage. There is no need to mount an auxiliary track in the ground or to the lintel.



CANTILEVER STRUCTURE

The materials and design solutions used enable heavy duty operation of the gate.



HIGH SPEED AND RELI- ABLE OPERATION

Features a reliable automatic operating unit.



SAFE

The gate is available with both the Totmann and the Automatik mode, depending on the required operation method.



Product description

General description

High-speed and reliable Traffic folding gate. Operation speed rated at 0.6m/s. Intended for heavy duty operation of around 250 cycles per day. Safe gate. Outfitted with safety systems: photocells and safety edges. The CE certificate confirms product compatibility with the provisions of the PN EN 13241-1 standard. The gate is available in a single-leaf and a double-leaf version. The gate is secured against corrosion by hot-dip galvanizing or by a combination of hot-dip galvanizing and coating with polyester paint (Duplex system).

Area of application

Intended use: The Traffic gate is a perfect solution for areas where the speed of operation and the number of daily opening cycles are of crucial importance. The gate combines the advantages of a double-leaf gate and a barrier, enabling permanent access control or traffic control.

Technical data

Gate leaf

The Traffic gate is a perfect solution for areas where the speed of operation and the number of daily opening cycles are of crucial importance. The gate combines the advantages of a double-leaf gate and a barrier, enabling permanent access control or traffic control.



Traffic double-leaf gate
with a 25x25 mm palisade infill

Gate infill

The gate is available with several different infills: 25x25mm, 30x18mm, 25x25 Caro section, ø 25mm round tube section or the Vega 2D Super mesh panel.



Traffic single-leaf right gate
with the Vega 2D Super mesh panel infill



Traffic single-leaf right gate
with a 25x25 mm palisade infill



Gate post

Each gate is supplied with load-bearing posts made of a section. The gate posts are fitted with base plates reinforced with ribs. The posts feature inspection openings.

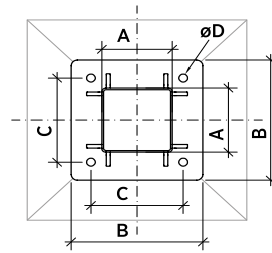

GATE POST DIMENSIONS

A	B	C	D
Post made of a 160x160 mm section			
	340	240	ø20

Fig. 1 Gate post cross-section.

Standard colours

DUPLEX system

The gates are available in a hot-dip galvanized or a galvanized and polyester coated version. The gates are available in the following colours as standard: RAL 5010, RAL 6005, RAL 7016, RAL 7030, RAL 9016 and RAL 9005 MAT.

RAL 5010	RAL 6005	RAL 7016
RAL 7030	RAL 9016	RAL 9005/MAT Black

Note: The colours and gloss grades presented in this publication are for reference only.

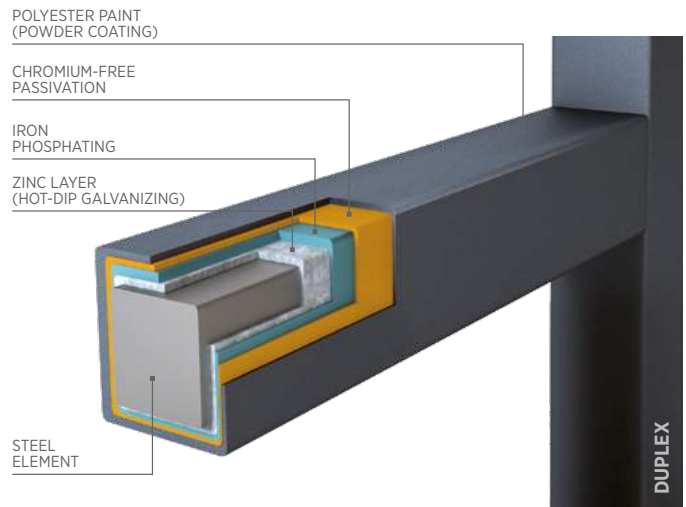

Automatic operating units

The Traffic high-speed gates are paired with the CAME Ferni F1024 automatic operating units. Operating speed up to 0.6 m/s. Intended use - heavy duty operation, up to 250 cycles per day.

The automatic operating units are installed in the top section of the load-bearing posts. Torque is transferred to the leaves through a folding arm system and a linkage system.

Drive units are controlled by Came ZLJ24 enclosed in a box with the IP 67 rating.

The drive unit is intended for operation in temperatures from -20 to +55°C



Came Ferni F1024



Drive unit model	Operation type	Mains	Motor supply	Power consumption	Protection rating	Opening time
Came FERNI F1024	heavy duty operation	1x230 [V]	24 [V]	0.18 kW	IP 54	adjustable



Ordered and design dimensions and installation dimensions

SINGLE-LEAF GATE



Ordering width of the gate (Sj) (clear opening width)	Gate height (H)	Width between posts	Leaf height from the floor	Post dimensions	Post height	Required space (without the box)	Required space (with the box)
1500-3000 mm	2000	Sj + 230	Ho + 100	160x160	2150	Sj + 950	Sj + 1100
	2100	Sj + 230	Ho + 100	160x160	2250	Sj + 950	Sj + 1100
	2200	Sj + 230	Ho + 100	160x160	2350	Sj + 950	Sj + 1100
	2300	Sj + 230	Ho + 100	160x160	2450	Sj + 950	Sj + 1100
	2400	Sj + 230	Ho + 100	160x160	2550	Sj + 950	Sj + 1100
	2500	Sj + 230	Ho + 100	160x160	2650	Sj + 950	Sj + 1100

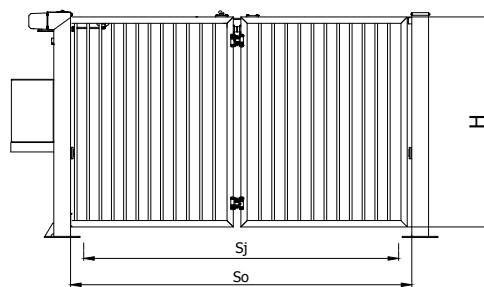

Sj - clear opening width (ordering dimension),
So - width between posts,
H - gate leaf height.

Traffic single-leaf right gate



**DOUBLE-LEAF
GATE**



Ordering width of the gate (Sj) (clear opening width)	Gate height (H)	Width between posts	Leaf height from the floor	Post dimensions	Post height	Required space (without the box)	Required space (with the box)
3000-6000 mm (min. co 50 mm)	2000	Sj + 250	Ho + 100	160x160	2150	Sj + 1050	Sj + 1250
	2100	Sj + 250	Ho + 100	160x160	2250	Sj + 1050	Sj + 1250
	2200	Sj + 250	Ho + 100	160x160	2350	Sj + 1050	Sj + 1250
	2300	Sj + 250	Ho + 100	160x160	2450	Sj + 1050	Sj + 1250
	2400	Sj + 250	Ho + 100	160x160	2550	Sj + 1050	Sj + 1250
	2500	Sj + 250	Ho + 100	160x160	2650	Sj + 1050	Sj + 1250

Sj - clear opening width (ordering dimension),
So - width between posts,
H - gate leaf height,

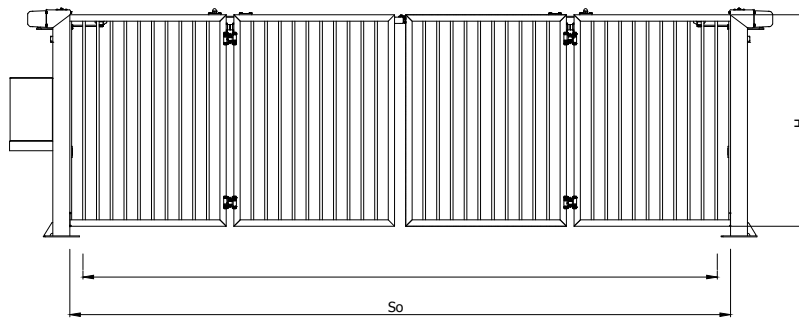

Traffic double-leaf gate



Accessories

Comfort and safety

Gate with posts, a complete Came drive unit and control unit, available with the Totmann (key switch integrated with the emergency stop, warning light, control unit, two actuators) or Automatik mode (key switch integrated with the emergency stop, warning light, photocell kit, two safety edges on the face edges of the leaves, two two-channel transmitters, radio, control unit, and two actuators)

Warranty

The product is covered by a 5-year corrosion protection guarantee.

CERTIFICATE

The TRAFFIC gates carry the CE marking in accordance with the 89/106/EEC; 98/37/EC; 73/23/EEC; 89/336/EEC directives on building products and comply with the requirements of the EN 13241-1 standard

Optional accessories

Signal light, induction loop detector, additional photocells, GSM control system, external code lock magnetic card reader (cards or fobs), additional transmitters.

Build a comprehensive industrial fencing system



WIŚNIEWSKI fences are a system of solutions ensuring comprehensive protection of your property. Our residential and industrial product range includes modern steel, profile, and panel fences. Reliable, high quality, and durable, our fences also boast an elegant and stylish look. WIŚNIEWSKI's comprehensive offer makes closing off your property simple and reflects great care for safety, security, and appearance. **Take advantage of our complete range and build your own fence.**

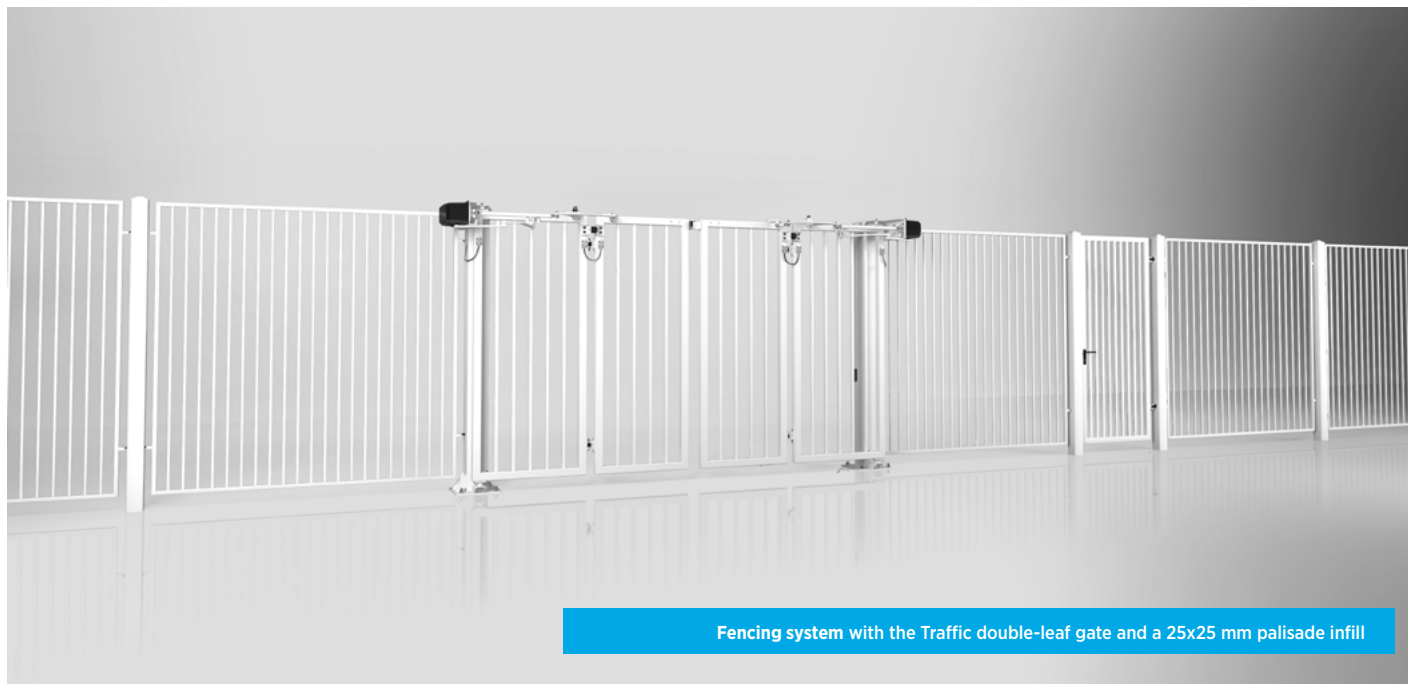

Fencing system with the Traffic double-leaf gate and a 25x25 mm palisade infill



Fence system with the Traffic double-leaf gate and the VEGA 2D Super mesh panel infill



WIŚNIEWSKI

GATES | WINDOWS | DOORS | FENCES

WIŚNIEWSKI Sp. z o.o. S.K.A.
PL 33-311 Wielogłowy 153
tel. +48 18 44 77 111
Fax +48 18 44 77 110

www.wisniowski.pl/en

N = 49° 40' 10" | E = 20° 41' 12"

Let us inspire you!
See other solutions from WIŚNIEWSKI!



The products shown in the pictures often feature special accessories and do not always correspond to their standard versions • The technical data sheet does not constitute an offer within the meaning of the Polish Civil Code • The manufacturer reserves the right to introduce changes without notice • NOTE: The colours shown in the technical data sheet are for reference only • All rights reserved • Copying and use, in part or in full, is prohibited without the consent of WIŚNIEWSKI Sp. z o.o. S.K.A. • TRAFFIC/11.19/EN