



PRODUCT DATASHEET
I-14FG OVERHEAD SECTIONAL
DOOR

Technical facts

Features

Max size: (W x H)*	5500 mm x 4250 mm
Frame thickness:	44 mm
Frame material:	Aluminium tubular frames
Filling:	Windows ≤DLW 3300mm, 1 pane >DLW 3300mm, 2 panes
Color outside:	Natural aluminium
Color inside:	Natural aluminium
Track types:	Standard: SL Optional: HL, LL, VL, HHL
Windows:	SH6: 6 mm HG
Electrical operation:	Optional: Automated operation, Access control, Safety functions

Performance

Opening/closing speed:	IDO7: 0.25 m/s IDO7 HD: 0.18 m/s IDO7 2H: opening 0.5 m/s, closing 0.25 m/s	
Life time expectations:	Door: 200000 door cycles or 10 years, when service/replacement program has been performed Springs: 20000 door cycles	
Resistance to wind load, EN 12424	Insulated panel sections	Class 3 (DLW ≤ 4250) Class 2 (4250 < DLW) (Higher classes on request)
	Framed sections	Class 3 (DLW ≤ 3650) Class 2 (3650 < DLW) (Higher classes on request)
Thermal transmittance, EN12428	4,8 W/(m²K) SH6, Double glass on request (4000 x 4000mm)	
Water penetration, EN12425	Class 3 (4000 x 4000 mm)	
Air permeability, EN12426	Class 3 (4000 x 4000 mm)	

* Higher wind load classification on request

Contents

Copyright and Disclaimer Notice.....	2
Technical facts.....	3
1 Description.....	6
1.1 General.....	6
1.2 Dimensions.....	6
1.2.1 Daylight width and daylight height.....	6
1.2.2 Section sizes.....	6
1.3 Door leaf.....	7
1.3.1 Construction.....	7
1.3.2 Material.....	7
1.3.3 Vertical cross-section.....	7
1.3.4 Colors.....	8
1.3.5 Windows.....	8
1.3.6 Seals.....	9
1.3.7 Wind reinforcement truss.....	9
1.3.8 Handle.....	9
1.3.9 Lock bolt.....	10
1.4 Balancing system.....	11
1.4.1 Safety devices.....	11
1.5 Track sets.....	12
1.5.1 General.....	12
1.5.2 SL - Standard Lift.....	12
1.5.3 SLL - Standard Lift Low.....	12
1.5.4 LL - Low Lift.....	12
1.5.5 HL - High Lift.....	12
1.5.6 HHL - High lift with spring package at the end of the horizontal track.....	13
1.5.7 VL - Vertical Lift.....	13
1.5.8 Special track sets.....	13
2 Available Options.....	14
2.1 Fixed sections.....	14
2.2 Optional colors.....	14
2.3 Collision protection.....	14
2.3.1 Track protection kit.....	14
2.3.2 Reinforced bottom profile.....	14
3 Operating system.....	15
3.1 Types of operation.....	15
3.2 Pull-down rope.....	15
3.3 Chain hoist.....	15
3.4 IDO7 Operator - C700 Door control system.....	16
3.4.1 IDO7 Operator.....	16
3.4.2 C700 Door control system.....	16
3.4.3 Electrical preparations.....	17
3.4.4 C700 Door control systems - Selection guidelines.....	17
3.4.5 C700 Door control systems - Selection guidelines for automation.....	17
3.5 Access and automation.....	19
3.5.1 Basic control functions.....	19
3.5.2 External control functions.....	19
3.5.3 Automatic control functions.....	19
3.5.4 Safety functions.....	20
3.5.5 Additional functions.....	21
4 CEN Performance.....	22
4.1 Lifetime expectation.....	22
4.2 Resistance to windload.....	22
4.3 Resistance to water penetration.....	22
4.4 Air permeability.....	23

4.5	Thermal transmittance.....	23
4.6	Operating forces and safe openings.....	23
5	Building and space requirements.....	24
5.1	Building preparations.....	24
5.1.1	Installation preparations.....	24
5.2	Space requirements.....	24
5.2.1	Space requirements SL.....	25
5.2.2	Space requirements HL.....	26
5.2.3	Space requirements HHL.....	27
5.2.4	Space requirements LL.....	28
5.2.5	Space requirements VL.....	29
	Index.....	30

1 Description

1.1 General

The Dynaco I-14FG overhead sectional door is one of the most stable overhead doors on the market.

It is an overhead sectional door, suitable for all types of buildings, with regard to both function and appearance. High flexibility makes it possible to install this door in almost every type of building.

The door slides up under the roof when opened, allowing free space around the door opening and leaving the door opening completely free.

The door is made of aluminium tubular profiles, filled with windows. The high light admission makes this door the ideal choice for working environments that require maximum lighting.

The Dynaco I-14FG overhead sectional door has been designed to meet all operational and safety requirements in the European Directives and the standards issued by the European Standardization Committee, CEN.

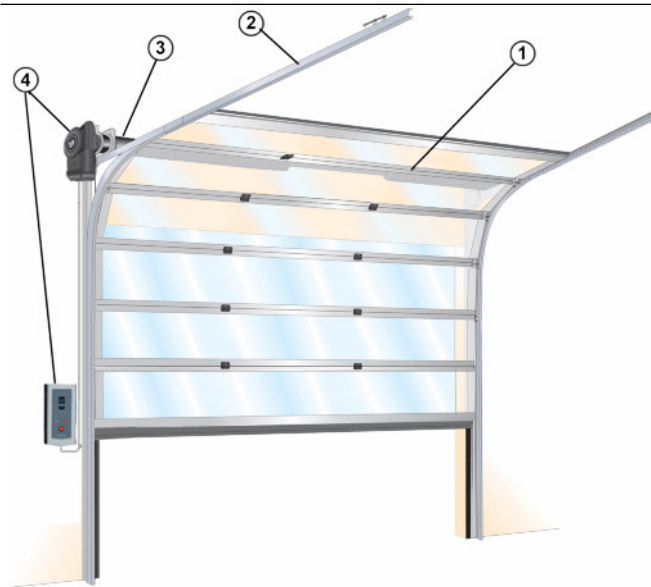

The door has 4 primary parts:

1. Door leaf
2. Track set
3. Balancing system
4. Operating system

1.2 Dimensions

1.2.1 Daylight width and daylight height

The Dynaco I-14FG overhead sectional door is delivered in the following size range:

	Daylight width	Daylight height
Min.:	2050 mm	1979 mm
Max.:	5500 mm	4250 mm

1.2.2 Section sizes

Section height:	400 - 600 mm*
Thickness:	44 mm

*The door leaf height is equally divided over the sections (standard).

Number of sections

DLH Frame bottom section	Number of sections
0000 - 1979	3
1980 - 2579	4
2580 - 3179	5
3180 - 3779	6
3780 - 4250	7

1.3 Door leaf

1.3.1 Construction

The Dynaco I-14FG overhead sectional door leaf has horizontal sections, connected together with hinges. The outer hinges of each section have rollers that run in the tracks.

The horizontal sections are aluminium tubular frames with full windows.

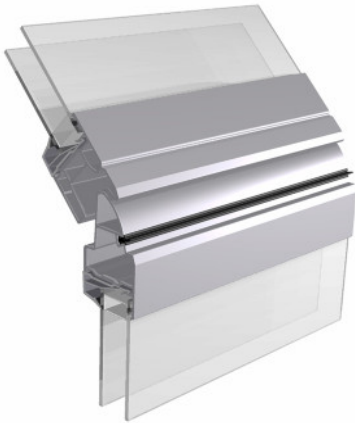

1.3.2 Material

The sections are made of tubular aluminium frames, equipped with windows.

The bottom section is a frame construction with windows, but can, if required, be delivered as an insulated panel.

1.3.3 Vertical cross-section

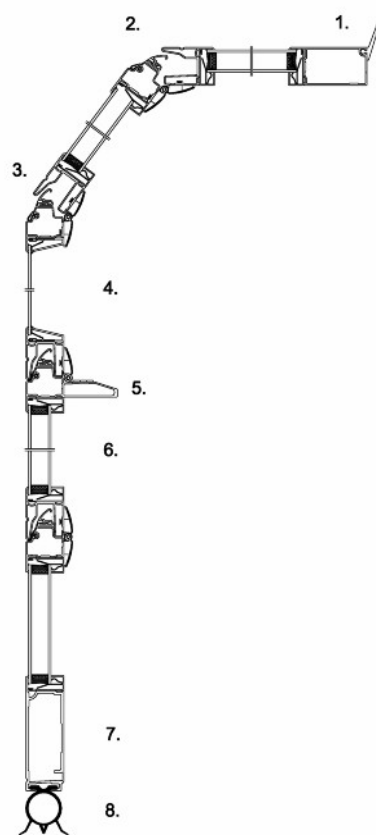

1. Top seal
2. Integrated finger pinch protection
3. Sealing in section joint
4. Single hardened 6 mm glass (standard)
5. Panel truss - wind reinforcement (if necessary)
6. Double glass, 27mm (on request)
7. Frame bottom section
8. Bottom seal

1.3.4 Colors

The Dynaco I-14FG overhead sectional door is available in any color on request. As standard, the frames are delivered in natural anodized aluminium.

1.3.4.1 Standard colors

Frames

- The frames are delivered as a standard in natural aluminium.

1.3.5 Windows

The frame construction allows full windows in all sections. The light opening is equal for all window types and depends on the dimensions of the door leaf.

1.3.5.1 SA/SH

SH6: Single hardened glass 6 mm

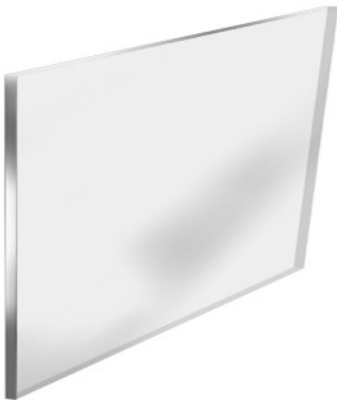

Double hardened glass on request

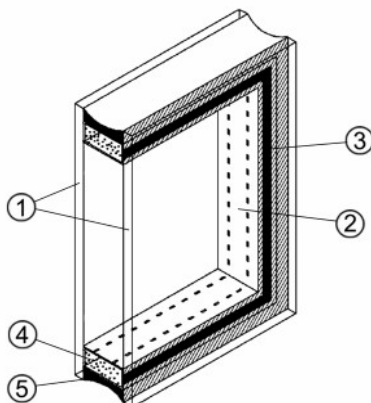

- Double hardened glass
- Aluminium distance frame
- Butyl sealing
- Absorbing siccative
- Silicone sealing

1.3.5.2 Number of windows

For windows the daylight width is divided into a fixed grid. The number of windows depends on the daylight width of the door.

Daylight width	No. of windows
2050 - 3300 mm	1
3301 - 5500 mm	2

1.3.6 Seals

The door is equipped with well designed seals on all sides that gives the door its excellent sealing abilities.

1.3.6.1 Top seal

The top seal is installed on the top panel to seal the gap between the panel and the wall. The EPDM rubber top seal ensures an optimal insulation and tightness.



1.3.6.2 Side seal

Installed on the track set to close the gap between the tracks and the door leaf. The double lip side seal design with insulation chambers ensures an optimal insulation and sealing.



1.3.6.3 Bottom seal

Installed on the bottom edge of the bottom panel, to act as a barrier as well as a shock absorber. The flexible EPDM rubber material and the O-shape provides continuous pressure on the floor, ensuring maximum sealing. The bottom seal is mounted in an ABS adapter for optimal insulation and reduced risk of condensation.



1.3.7 Wind reinforcement truss

Wider door panels and panels with windows are reinforced with metal profiles that act as trusses. These trusses reduce bending of the panel caused by wind loads or when the door leaf is in the horizontal position and is bending under its own weight. The wind reinforcement truss is integrated in the aluminium profiles.

1.3.8 Handle

For manual operation, every Dynaco I-14FG overhead sectional door is provided with a solid, easy to grip handle.



1.3.9 Lock bolt

A standard Dynaco I-14FG overhead sectional door is equipped with a lock bolt. The lock bolt locks the door from the inside, without the use of a key. The lock bolt has a hole in the latch, to allow the use of a 12mm padlock.

The Lock bolt is not visible from the outside.



1.4 Balancing system

The balancing system balances the door by applying a force nearly equal to the weight of the door leaf. This allows the door leaf to be moved up and down manually, and to stay open in any position.

The system is installed on the top or the end of the track set and works as follows: Two torsion springs are installed on a shaft above the door opening. This shaft has a cable drum on each end from which door cables run to the bottom corners of the door leaf. Turning the shaft moves the door up or down.

1.4.1 Safety devices

The balancing system supports heavy forces. In case of a spring or cable break, its counterforce is lost. The door is therefore equipped with two safety devices that can block downward door movement:

- Spring Break Device (standard)
- Cable Break Device (optional)

1.4.1.1 Spring break device

The Spring Break Device is delivered with all Dynaco I-14FG overhead sectional doors.

In the event of a spring break, the sudden drop force activates the Spring Break Device. The shaft will be locked in less than 300mm of door movement.

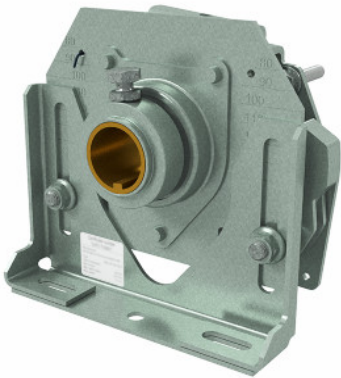

1.4.1.2 Cable break device (CBD)

The Cable Break Device (CBD) is an optional safety device. In the event of a cable failure the door leaf will be blocked in less than 300 mm to avoid damage.



1.5 Track sets

1.5.1 General

The track set supports the door leaf on its rollers and guides it upwards. The selection of the appropriate track set is based on various factors:

- Available head room
- Door height
- Type of vehicles
- Presence of roof obstructions, pipes and overhead crane beams.

The track sets below cover most applications. Other applications are available on request.

1.5.2 SL - Standard Lift

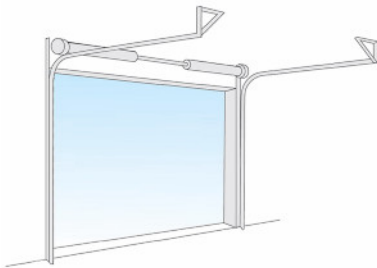

- Building type: Most standard industrial buildings.
 - Benefits: Optimal design for common buildings.
- The Standard Lift track set, with the spring package just above the door, is the most common solution

1.5.3 SLL - Standard Lift Low

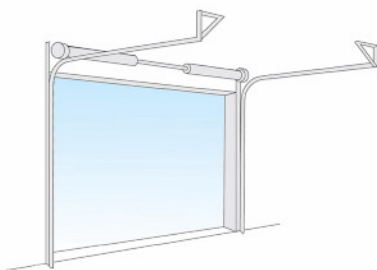

- Building type: Low ceilings.
- Benefits: Achieve more daylight height with a limited head room.

The Standard Lift Low track set is a variant of the Low Lift where the spring package is installed just above the door.

1.5.4 LL - Low Lift

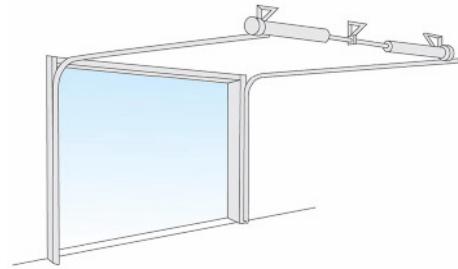

- Building type: Low ceilings.
 - Benefits: Achieve maximum daylight height with minimum head room.
- Same as standard lift, but with the spring package at the end of the horizontal tracks.

1.5.5 HL - High Lift

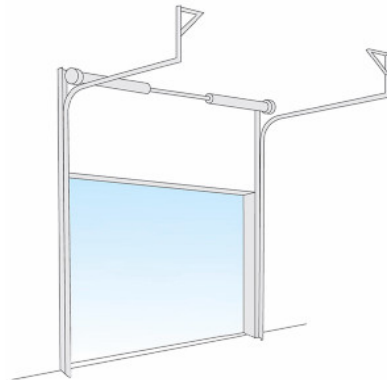

- Building type: High ceilings. On the High Lift track set the spring package is placed high above the door.
- Benefits: This track type allows high vehicles to cross along the door opening without obstructions of the horizontal tracks.

This track type is used when the space above the door is considerable, and is needed for work and traffic, e.g.: high vehicles.

1.5.6 HHL - High lift with spring package at the end of the horizontal track

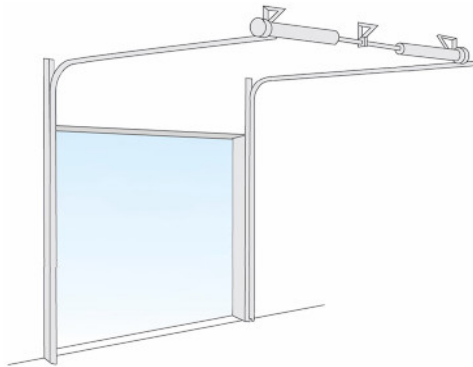

- Building type: High ceilings. Used when space between ceiling and lower edge of horizontal track is limited.
 - Benefits: Achieve maximum highlift with minimum head room.
- High lift hardware with the spring package placed in the end of the horizontal track.

1.5.7 VL - Vertical Lift

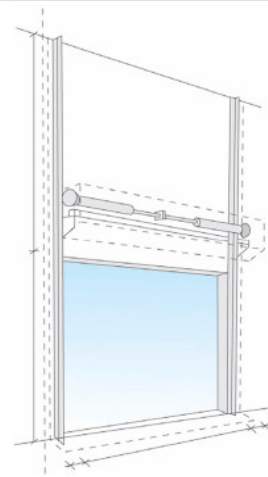

- Building type: Very high ceiling and high working space requirements.
 - Benefits: Allows high vehicles to cross along the door opening without any obstructions.
- If the space between the daylight height and the roof is sufficient, with this track type, the door can be opened vertically.

1.5.8 Special track sets

The Dynaco I-14FG overhead sectional door track set can be custom designed to make the door fit in places that seem quite impossible. Our door technicians can solve installation problems where the door must share space with ventilation systems, crane beams, etc. For example:

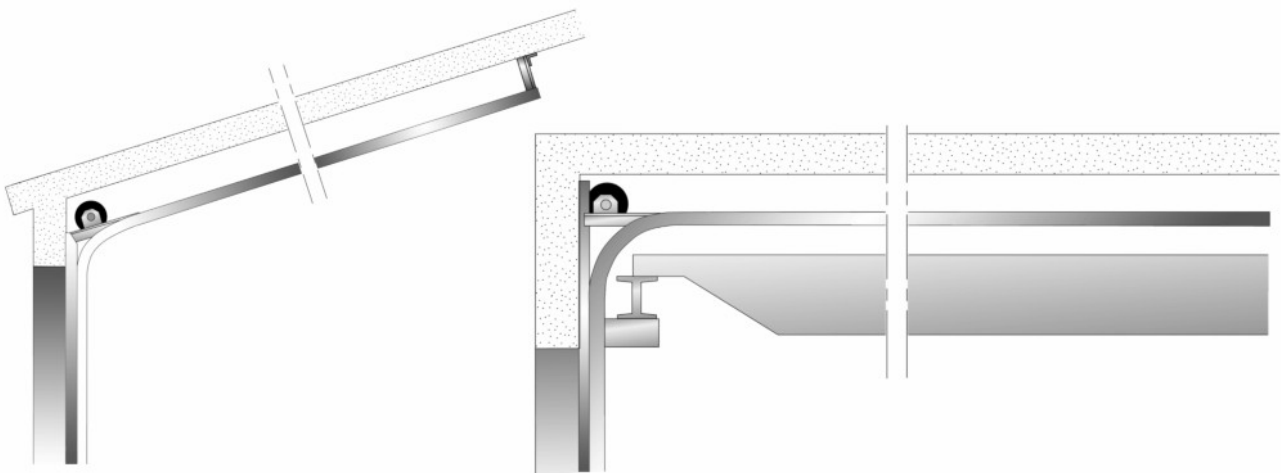

2 Available Options

2.1 Fixed sections

Fixed sections can advantageously fill space around new doors that are smaller than the wall opening. Fixed sections are available in top and side sections. Fixed sections are supplied in the same color and construction as the door leaf.

A fixed section can be provided with a passdoor for two reasons: Safety and energy cost reduction.

- Safety: Putting a separate passdoor in a fixed section next to the industrial door separates pedestrian and vehicle traffic.
- Energy cost reduction: The opening space for frequent pedestrian traffic is minimized.

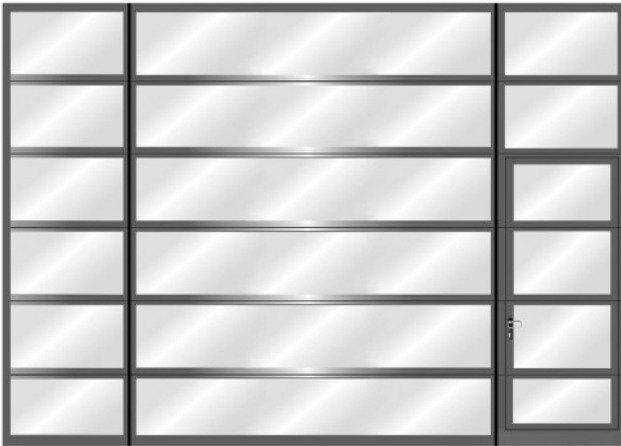

2.2 Optional colors

Frames

- Factory painting, all RAL colors

2.3 Collision protection

2.3.1 Track protection kit

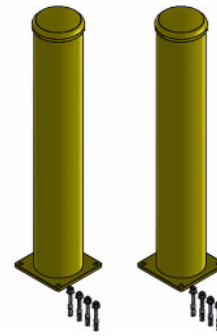

The track protection kit is designed to protect the tracks being accidentally hit by vehicles. The kit includes two bollards and fasteners. The bollards are powder coated with a UV protective paint and the top can be removed to fill the bollard with sand or concrete. The bollards are 1000 mm high with a diameter and thickness of 159×3 mm and the plate is 200 mm square. The distance between (any part of) the door and the bollards should be at least 500 mm to prevent people from getting stuck between the bollards and the door.

2.3.2 Reinforced bottom profile

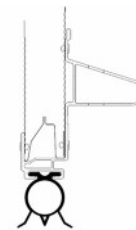

A special aluminium bottom profile with an integrated reinforcement is available if extra collision protection is needed.

3 Operating system

3.1 Types of operation

The Dynaco I-14FG overhead sectional door can be opened and closed manually. They are also prepared for electrical operation. Electrically operated doors can be controlled by hand or be fully automatic. Traffic frequency, climate requirements and the weight of the door play a key role in choosing the optimal control system.

3.2 Pull-down rope

The Dynaco I-14FG overhead sectional door can be operated manually with a pull-down rope. The pull-down rope is directly connected to the door leaf.

3.3 Chain hoist

For heavier doors, a chain hoist allows easier manual door operation.

There are 2 types of chain hoist:

- T-hoist: Geared (ratio 1:4) chain transmission directly connected to the shaft. Recommended for doors up to 250 kg (For all shaft types).
- U-hoist: Geared (ratio 1:3) indirect chain transmission. Recommended for doors of 250 kg and above (For all shaft types).

T-hoist:

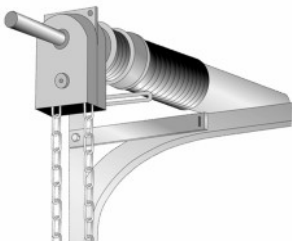

U-hoist:



The IDO7 can also be equipped with an integrated geared (ratio 1:3,5) chain hoist.



3.4 IDO7 Operator - C700 Door control system

The IDO7 operator is a combination of the IDO7 operator and a C700 Door control system. The regular IDO7 model is available for doors up to 400 kg. The IDO7 HD model is available for doors up to 800 kg. The double speed IDO7 2H model is available for doors up to 250 kg.

3.4.1 IDO7 Operator

One main part of the system is the operator: an electric motor which drives the balancing shaft with the cable drums and torsion springs. It can be retrofitted to an already installed door. The IDO7 operator is mounted directly on the balancing shaft and does not require any special wall reinforcement (except IDO7 HD).

With a built-in frequency converter the IDO7 operator has a soft start and soft stop. Smoothly accelerating and decelerating at the end positions reduces the wear and tear and noise level of the door. To comply with regulations a safety stop will give a hard stop.

Key features:

- Smooth and silent
- Soft start and stop
- Fits all track types and shafts
- Life time: 84000 - 300000 door cycles (depending on weight and temp.) e.g.:
 - Temp. 0 °C - +40 °C/weight 250 kg = 300000 cycles
 - Temp. -20 °C - +60 °C/weight 400 kg = 84000 cycles



3.4.2 C700 Door control system

The C700 Door control system is one of the most advanced control units that is prepared for one or more physical upgrades from the entire range of automation systems. An automation system allows door operation by sensors or remote control.

This control unit contains a 3-digit diagnostics display that allows efficient troubleshooting and displays the number of door cycles. Together with the service indicator, this extra feature allows advanced maintenance planning to users where the door is an essential element of internal logistics.



3.4.3 Electrical preparations

The manually operated door needs no electrical supply.

For an electrically operated door, the following environment criteria and electrical supplies are required for the operator to function properly:

	IDO7	IDO7 HD	IDO7 2H
Voltage supply: +/- 10%	230V AC 1-phase 50/60Hz	230V AC 1-phase 50/60Hz	230V AC 1-phase 50/60Hz
Power:	0,37 kW	0,6 kW	0,37 kW
Degree of protection:	IP65, with connector IP44	IP65, with connector IP44	IP65, with connector IP44
Allowed door weight, max.:	400 kg	800 kg	250 kg
Temperature working range:	-20 °C to +55 °C*	-20 °C to +55 °C*	-20 °C to +55 °C*
Operating factor:	ED = 30% S3 10 min. intermittent	ED = 30% S3 10 min. intermittent	ED = 30% S3 10 min. intermittent
Mounting preparations:	-	When installing on the wall, an extra attachment angle is required with > 500N per fixation point.	

* At low temperatures the first few cycles may be run with reduced speed to prolong the operator's lifetime. Can be equipped with a heater for a working range down to -30°C.

3.4.4 C700 Door control systems - Selection guidelines

Functions included	C700
	
Open (by impulse)	<input checked="" type="checkbox"/>
Open (hold to run)	<input type="checkbox"/>
Stop	<input checked="" type="checkbox"/>
Close (by impulse)	<input checked="" type="checkbox"/>
Close (hold to run)	<input type="checkbox"/>
Reduced opening	<input checked="" type="checkbox"/>
Safety edge	<input checked="" type="checkbox"/>
Open function	<input checked="" type="checkbox"/>
One button function	<input checked="" type="checkbox"/>
Display (diagnostics)	<input checked="" type="checkbox"/>
Service indicator	<input checked="" type="checkbox"/>

Standard Option / Available

3.4.5 C700 Door control systems - Selection guidelines for automation

The "Automation D-kits" are packages of common combinations. These kits can also be supplemented by "additions to D-kits".

Automation D-kits	D1	D2	D3	D4	D5	D6
Interlocking	<input checked="" type="checkbox"/>	<input checked="" type="checkbox"/>	<input checked="" type="checkbox"/>	<input checked="" type="checkbox"/>	<input checked="" type="checkbox"/>	<input checked="" type="checkbox"/>
Magnetic loop		<input checked="" type="checkbox"/>		<input checked="" type="checkbox"/>		<input checked="" type="checkbox"/>
Traffic lights - Green + Red					<input checked="" type="checkbox"/>	<input checked="" type="checkbox"/>
Warning lights - Red	<input checked="" type="checkbox"/>			<input checked="" type="checkbox"/>		
Additions to D-kits						
Warning lights - Green	<input type="checkbox"/>	<input type="checkbox"/>	<input type="checkbox"/>	<input type="checkbox"/>		
Traffic lights - Green + Red	<input type="checkbox"/>	<input type="checkbox"/>	<input type="checkbox"/>	<input type="checkbox"/>		
Relay box	<input type="checkbox"/>	<input type="checkbox"/>	<input type="checkbox"/>	<input type="checkbox"/>	<input type="checkbox"/>	<input type="checkbox"/>
Radar	<input type="checkbox"/>	<input type="checkbox"/>	<input type="checkbox"/>	<input type="checkbox"/>	<input type="checkbox"/>	<input type="checkbox"/>

Standard Option / Available

The following options can be individually selected to add functionality to the control unit.

Functions optional	C700
	
Complete kits	
Automation D-kits	<input type="checkbox"/>
Basic control functions	
Interlocking	<input type="checkbox"/>
External control functions	
External pushb. box	<input type="checkbox"/>
Pull-rope switch	<input type="checkbox"/>
Remote control open/stop/close	<input type="checkbox"/>
Remote control 1-button function	<input type="checkbox"/>
Automatic control functions	
Automatic closing	<input type="checkbox"/>
Photocell open door	<input type="checkbox"/>
Safety functions	
Safety photocell (1 or 2)	<input type="checkbox"/>
French safety logic	<input type="checkbox"/>
Additional functions	
UPS Battery backup	<input type="checkbox"/>
Relay box	<input type="checkbox"/>

■ Standard Option / Available

3.5 Access and automation

Dynaco offers a wide range of functions that allows advanced opening and safety control. Please refer to the specification sheet of the control units to see which functions apply to which models.

3.5.1 Basic control functions

3.5.1.1 Interlocking

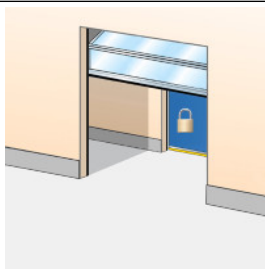

Developed for climate control or safety; If door A is open, door B cannot be opened. If door B is open, door A cannot be opened. An interlocked door can remember an up-command, if selected via a micro switch.

3.5.1.2 Reduced opening

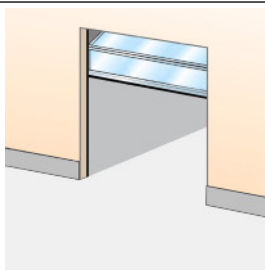

When it is unnecessary or undesirable to fully open a door, an additional switch can be used to open the door to a pre-programmed reduced opening position.

3.5.2 External control functions

3.5.2.1 External push button box

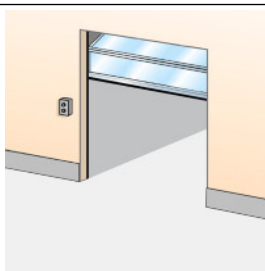

An extra control box is installed outside the building or inside close to the door if the main control unit needs to be installed away from the door opening. Installed on the inside or outside wall beside the door.

3.5.2.2 Pull-rope switch

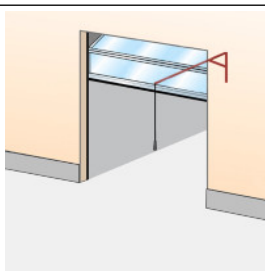

A pull-rope switch above the door opening can be operated from e.g. a forklift truck. Pulling the rope opens a closed door or closes an opened door. Installed on the inside construction above the door.

3.5.2.3 Remote control

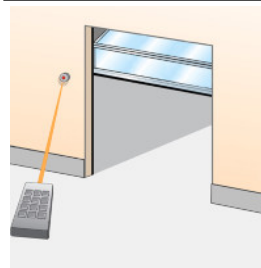

A hand-held radio transmitter allows door operation from a vehicle or any position within 50-100 meters from the receiver and aerial at the door. For closing, the door can be provided with a photocell beam. Receiver installed in control unit, antenna installed on the wall beside the door.

3.5.3 Automatic control functions

3.5.3.1 Magnetic loop

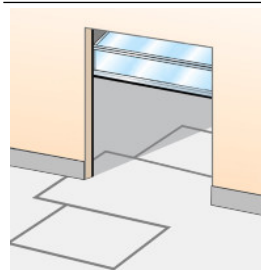

A sensor in the floor detects a metal object (usually forklift trucks, pallet trucks) and opens the door automatically. This is an ideal solution for frequent vehicle traffic. Installed on the outside, inside or both sides of the door in the floor.

3.5.3.2 Radar

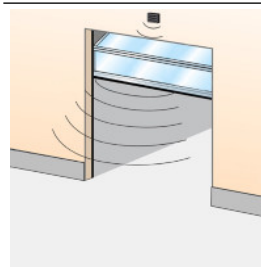

An infrared sensor above the door detects an object (person, vehicle) within a specified distance from the door and opens the door automatically. This is an ideal solution for frequent vehicle or personal traffic. Often combined with automatic closing. Installed on the inside or outside wall above the door.

3.5.3.3 Photocell open door

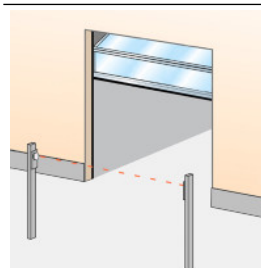

A set of photocells on pillars, on each side of the door. When a person or vehicle passes between the photocells, the beam is interrupted and the door opens. Photocells installed on pillars, away from the door.

3.5.3.4 Automatic closing

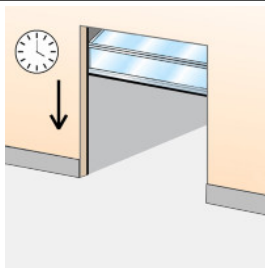

A programmable timer that closes the door after a specified time, counted from either the fully open position and/or from passing through the photocell beam.
Adjustable micro switches in control unit.

3.5.4.4 Warning lights - Red

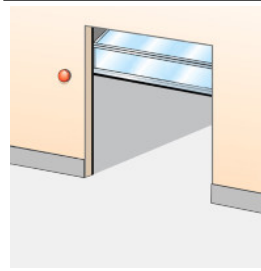

Two red warning lights giving information on the current door behaviour. Flashing light before or during door movement.
Optional: Continuous light before and during door movement.
Installed on the inside and outside wall beside the door.

3.5.4 Safety functions

3.5.4.1 Safety edge

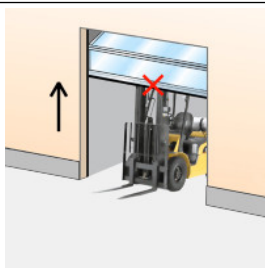

As a standard, all doors that have the impulse-close function or any form of automated closing, are equipped with a safety edge. The pneumatic sensor in the bottom seal detects any obstruction under a closing door and reverses the door.
Installed in the bottom seal.

3.5.4.5 Warning lights - Green

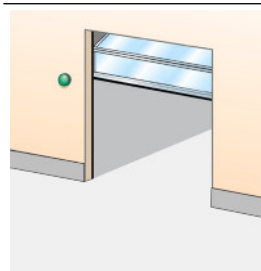

One or two green warning lights indicating the open position of the door by continuous light signal.
Installed on the inside and/or outside wall beside the door.

3.5.4.2 Safety photocells 1-channel

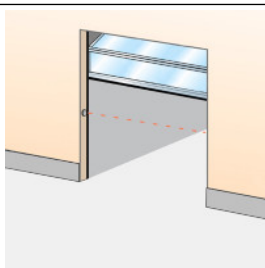

A set of a photocell transmitter and receiver is installed in the door opening. If the photocell beam is interrupted during closing, the door will stop and reverse to the fully open position.
Installed in the door opening.

3.5.4.6 Traffic lights - Red & Green

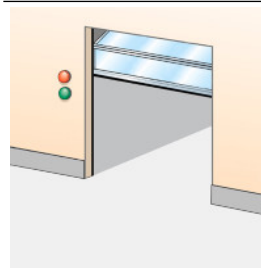

If traffic through a door needs to be directed; two red and two green traffic lights can be installed to indicate traffic direction. From the side where a vehicle is first detected to approach the door, the green traffic light comes on. The opposing side shows a red traffic light. Traffic from this direction must give way to the other.
Usually installed in e.g. parking garages.
Installed on the inside and outside wall beside the door.

3.5.4.3 Safety photocells 2-channel

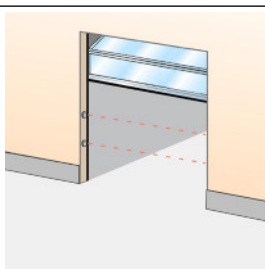

Two sets of photocell transmitter and receiver are installed in the door opening. If one or both photocell beams are interrupted during closing, the door will stop and reverse to the fully open position.
Installed in the door opening.

3.5.5 Additional functions

3.5.5.1 UPS battery backup



When mains failure cannot be permitted or an increased risk of mains failure is predicted, the UPS battery backup system can be installed to store enough energy for 5 door cycles. Installed on the inside wall beside the door.

3.5.5.2 Relay box



A sealed connection box makes it possible to safely connect external high-voltage equipment.

4 CEN Performance

4.1 Lifetime expectation

Door: 200000 door cycles or 10 years, when service/replacement program has been performed
Springs: 20000 door cycles

4.2 Resistance to windload

EN12424

Test result	Class 3 (\leq DLW 3300 mm)
	Class 2 ($>$ DLW 3300 mm)

Class	Pressure Pa (N/m ²)	Specification
0	-	No performance determined
1	300	
2	450	
3	700	
4	1000	
5	$>$ 1000	Exceptional : Agreement between manufacturer and supplier

Door size 4000 x 3450 mm

4.3 Resistance to water penetration

EN12425

Test result	Class 3 (no passdoor)
-------------	-----------------------

Class	Pressure Pa (N/m ²)	Specification
0	-	No performance determined
1	30	Waterspray for 15 minutes
2	50	Waterspray for 20 minutes
3	$>$ 50	Exceptional : Agreement between manufacturer and supplier

4.4 Air permeability

EN12426	Without passdoor
Test result	Class 3
Class	Air permeability dp at a pressure of 50 Pa (m³/m²/h)
0	-
1	24
2	12
3	6
4	3
5	1,5
6	Exceptional : Agreement between manufacturer and supplier

4.5 Thermal transmittance

EN12428	Single glass	Double glass
Thermal transmittance	4,8*	On request

Door size 4000 x 4000 mm

4.6 Operating forces and safe openings

EN12453 & EN12604	Crushing force N	Crushing force N	Crushing force N
Opening gap mm	200 mm from lateral border right from outside	In the middle of the door opening	200 mm from lateral border left from outside
50 mm	passed	passed	passed
300 mm	passed	passed	passed

The crushing force is the force needed for the safety edge to be activated. The maximum force allowed, according to EN12453 safety in use of power operated doors is 400 N within a maximum period of time of 0.75s. With standard light curtain there is no crushing force.

5 Building and space requirements

5.1 Building preparations

5.1.1 Installation preparations

The Dynaco I-14FG overhead sectional door is shipped in parts and installed on-site. All necessary installation material is included. For every track type Dynaco offers specific installation kits to position the door in the building facade.

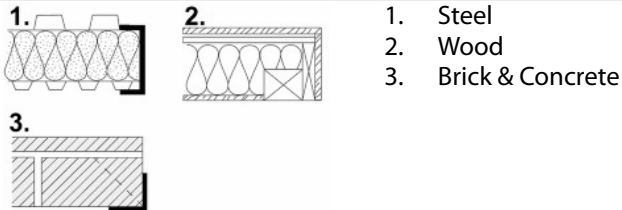

5.2 Space requirements

DLH	= Daylight Height	The height of the clear opening
DLW	= Daylight Width	The width of the clear opening
D	= Depth	The space between the inner side of the wall and the end of the horizontal track construction
h	= Excess height	The extra space required above the daylight height.
SL	= Side space Left	The space required for tracks beside the daylight width.
SR	= Side space Right	The space required for tracks beside the daylight width.

The grey marked area in the illustrations shows the free space required by door movement. Extra space requirements for electrically operated doors are stated in the operator specifications. Extra space requirements for passdoors are stated in the passdoor specifications.

5.2.1 Space requirements SL

h	485 mm (DLH ≤ 4500 mm) 510 mm (DLH > 4500 mm) 575 mm (with center operator)
SL/SR	132 mm Manual, 212 mm Hoist-D/T, 278 mm Hoist-U, 270 mm Operator, 310 mm Operator+Hoist (with outer support bearing + 45 mm)
D	DLH + 600 mm For details see the specific building preparation drawings

Side and top view

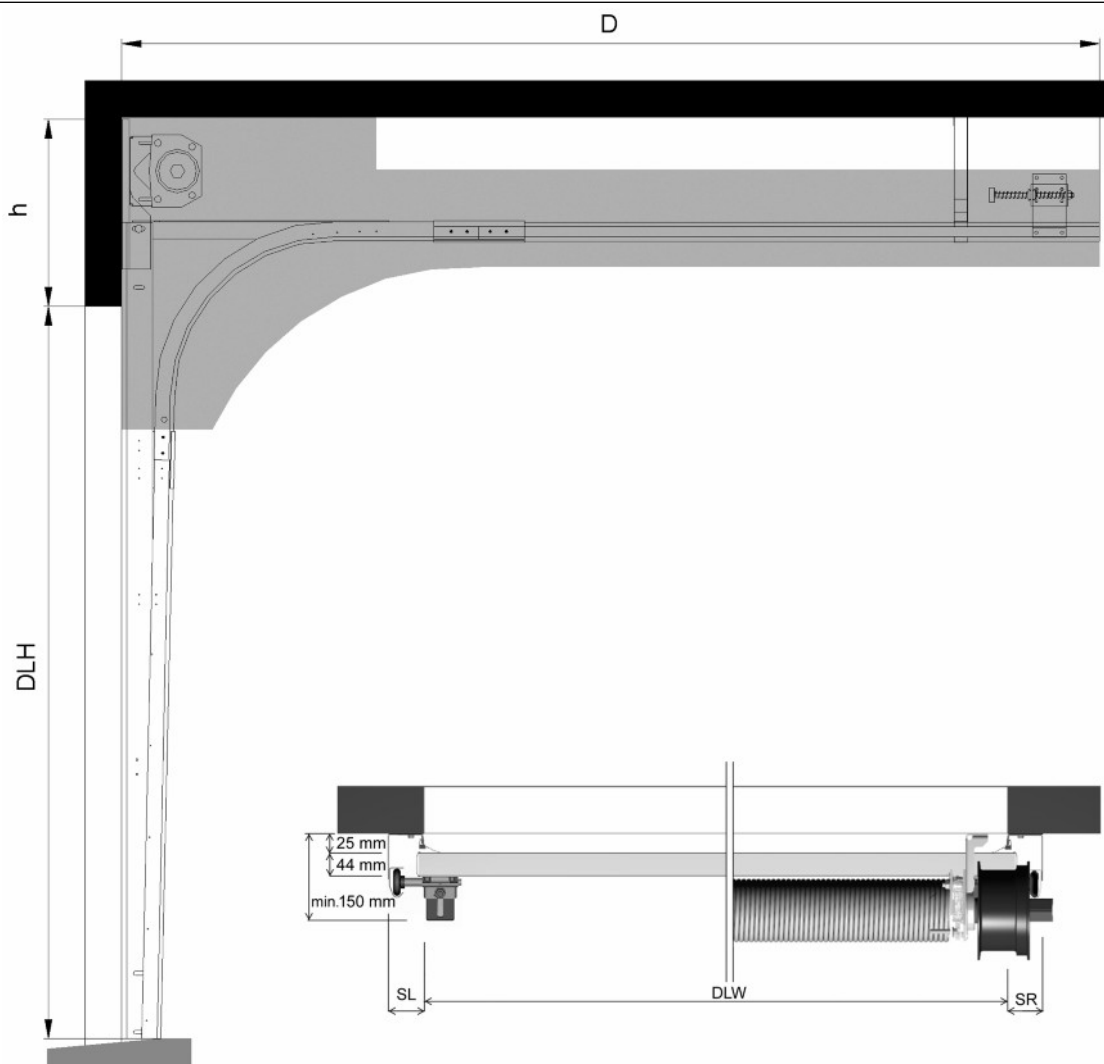

5.2.2 Space requirements HL

	HL	HL with Beam
h	HL+320 mm (HL ≤ 3321 mm) HL+370 mm (HL > 3321 mm) HL +400 mm (with center operator)	HL+220 mm
SL/SR	132 mm Manual, 212 mm Hoist-D/T, 278 mm Hoist-U, 270 mm Operator, 310 mm Operator+Hoist (with outer support bearing + 45 mm)	106 mm Manual, 212 mm Hoist-D/T, 278 mm Hoist-U, 312 mm Operator, 352 mm Operator+Hoist (with outer support bearing + 64 mm)
D	DLH - HL + 950 mm	DLH - HL + 950 mm

For details see the specific building preparation drawings

We would advise the following doors to be installed on a frame, equipped with an A-65 top seal.

- Doors DLW ≥ 4050 mm with a dark outside colour, frequently exposed to solar heat.

Side and top view

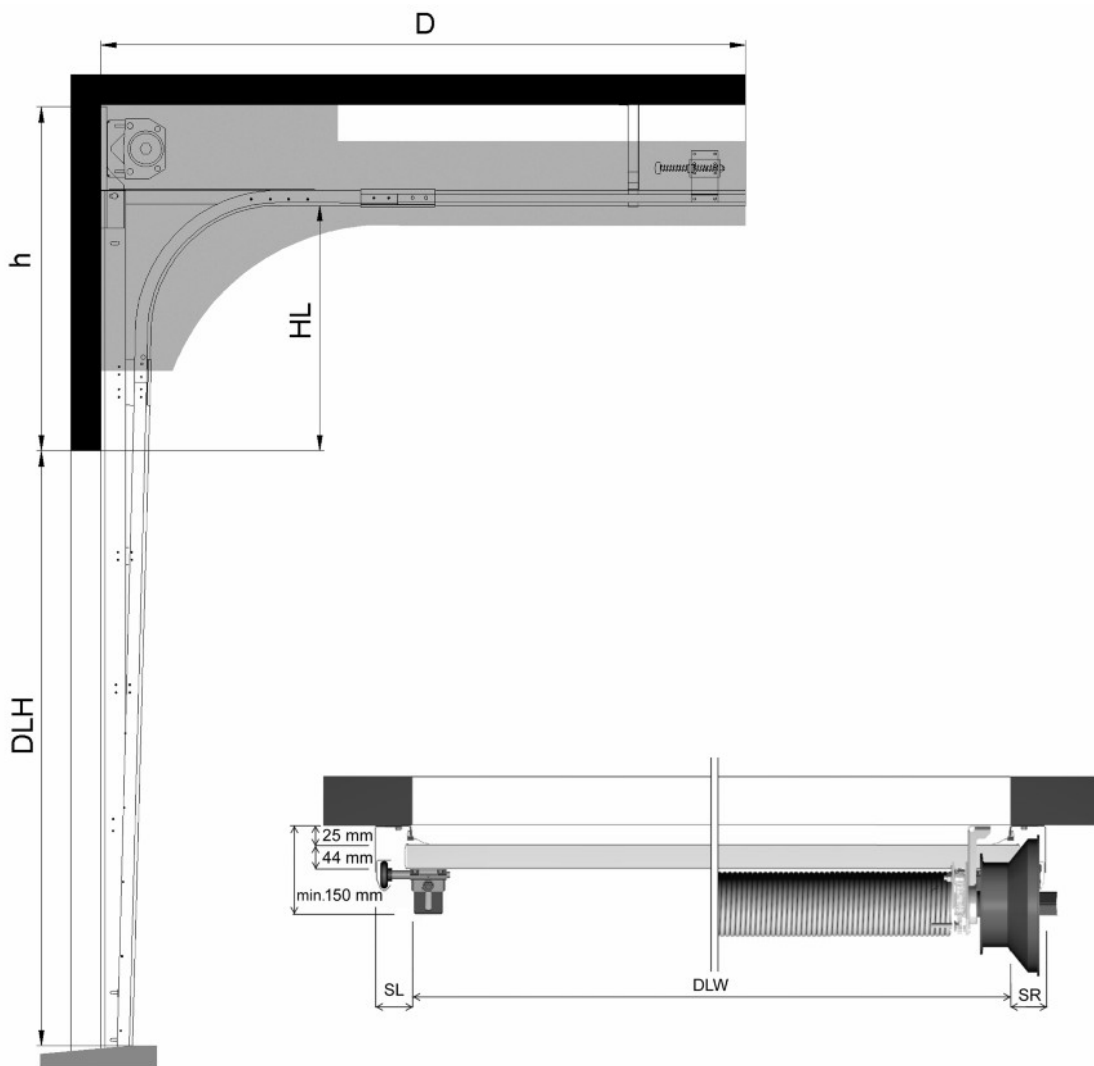

5.2.3 Space requirements HHL

h	HL+260 mm (HL ≤ 3321 mm), HL+285 mm (HL > 3321 mm)
SL/SR	132 mm Manual, 228 mm Hoist-D/T, 278 mm Hoist-U, 304 mm Operator, 344 mm Operator+Hoist (with outer support bearing + 45 mm)
D	manual: DLH - HL + 1200 mm electric: DLH - HL + 1300 mm

For details see the specific building preparation drawings

We would advise the following doors to be installed on a frame, equipped with an A-65 top seal.

- Doors DLW ≥ 4050 mm with a dark outside colour, frequently exposed to solar heat.

Side and top view

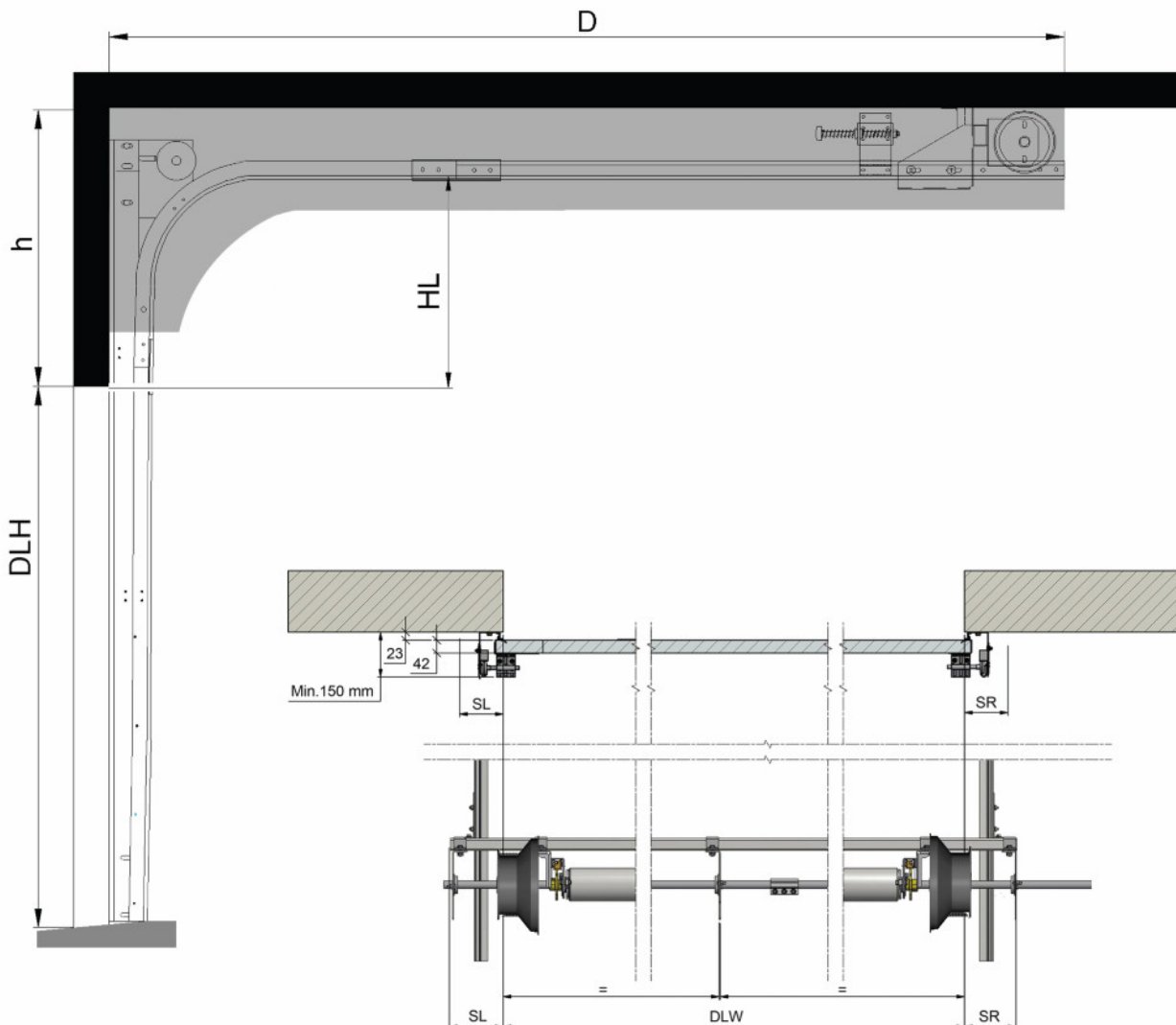

5.2.4 Space requirements LL

h	265 mm (\leq 250 kg) 300 mm ($>$ 250 kg)
SL/SR	132 mm Manual, 228 mm Hoist-D/T, 278 mm Hoist-U, 304 mm Operator, 344 mm Operator+Hoist (with outer support bearing + 45 mm)
D	manual: DLH + 1200 mm electric: DLH + 1250 mm
For details see the specific building preparation drawings *** With low threshold pasdoor only	

Side and top view

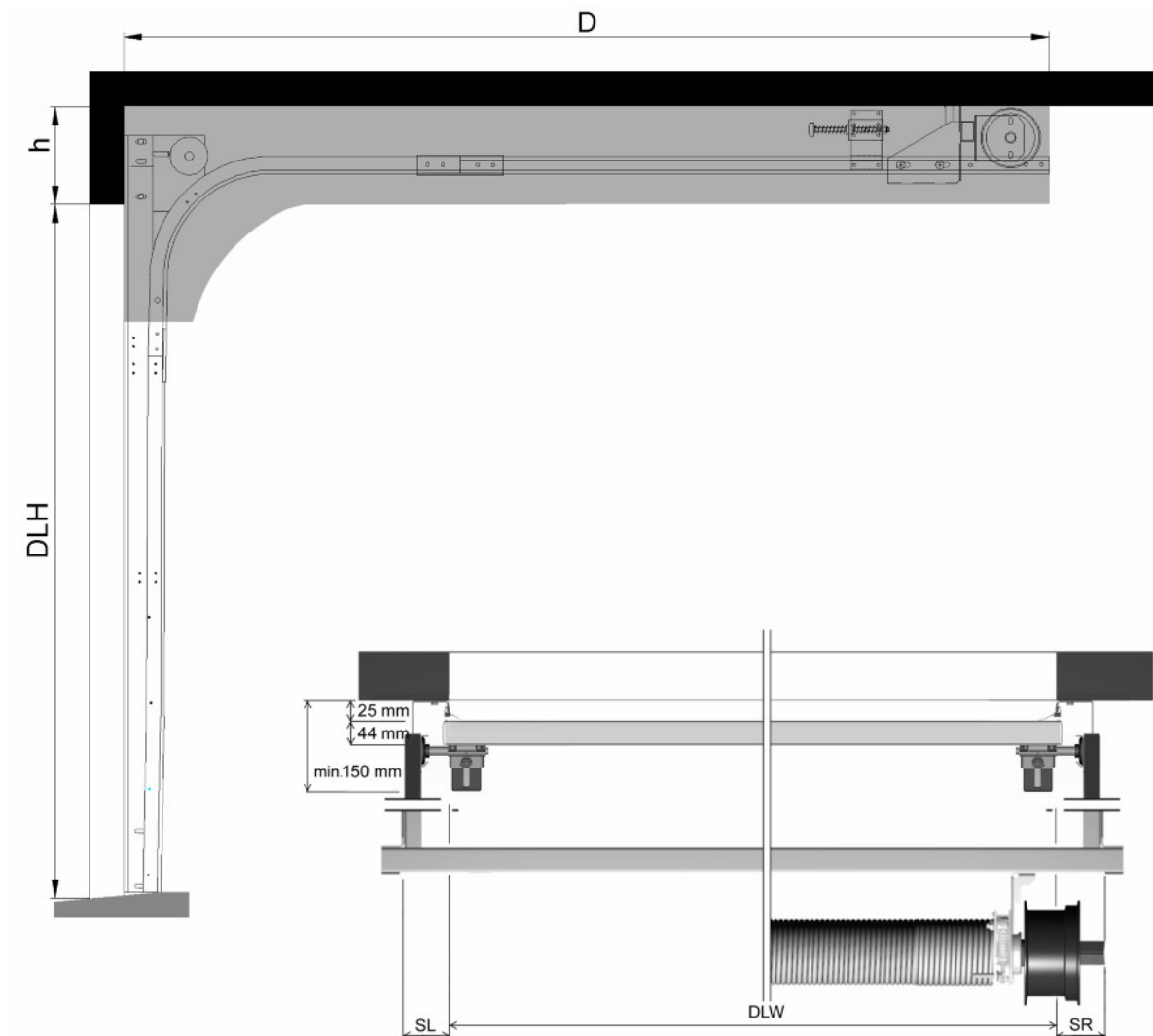

5.2.5 Space requirements VL

h	DLH + 365 mm
SL/SR	110 mm Manual, 216 mm Hoist-D/T, 278 mm Hoist-U, 312 mm Operator, 352 mm Operator+Hoist (with outer support bearing + 64 mm)
D	VLA = 500 mm VLT = 525 mm (manual + operator left/right); 625 mm (operator center) VLS = 525 mm

For details see the specific building preparation drawings

- VL doors: DLW ≤ 3000 mm and DLH ≤ 3350 = VLA = no beam installed
 - VL doors: DLW > 3000 mm or DLH > 3350 = VLT = installed with beam to support the balancing system
- We would advise the following doors to be installed on a frame, equipped with an A-65 top seal.
- Doors DLW ≥ 4050 mm with a dark outside colour, frequently exposed to solar heat.

Side and top view

