

POOCK
P R O D U C T S

sterili

COMBILOK[®] G²

THE NEXT LEVEL IN SAFETY

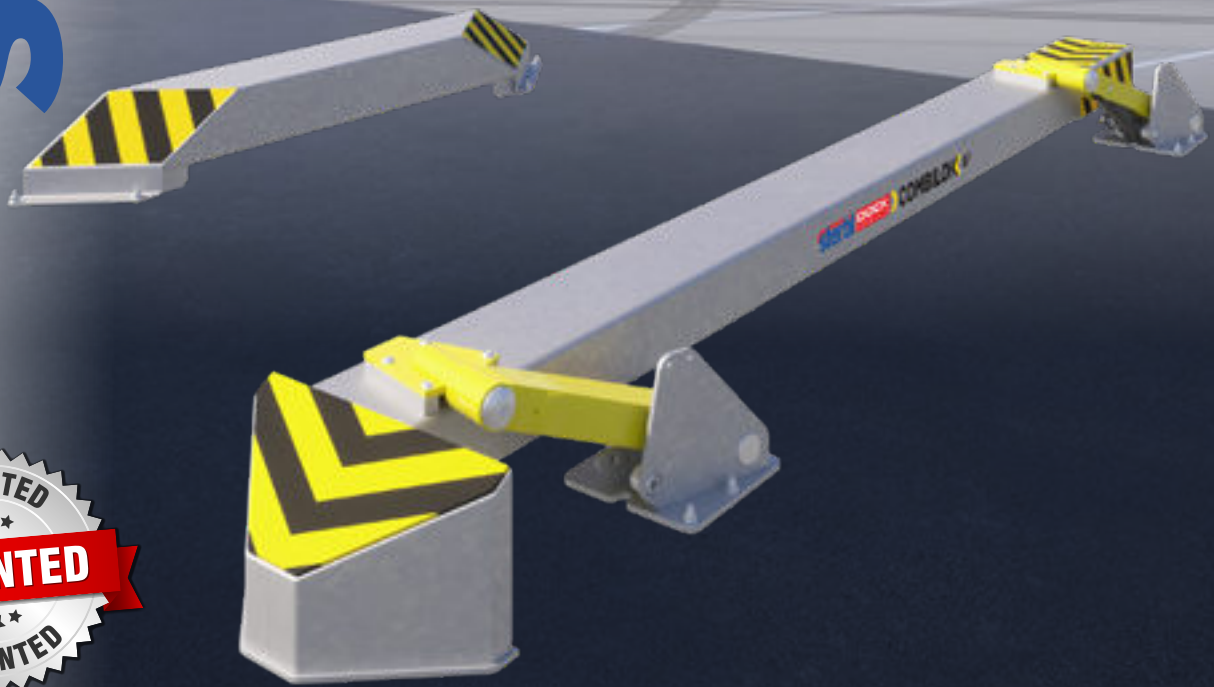

AUTOMATIC UNIVERSAL VEHICLE RESTRAINT SYSTEM

SUPERIOR SOLUTIONS FOR LOADING AND UNLOADING



NO.1 IN VEHICLE RESTRAINTS

Stertil Dock Products as market leader and first in the industry with the legendary COMBILOK® has more than 25 years of unprecedented experience and technical expertise in the automatic vehicle restraint market. This has been manifested in the research and development of the next generation COMBILOK®, the G². Stertil Dock Products provides quality, customised and technically advanced loading bay dock equipment solutions throughout the world.

These superior solutions are designed, developed and manufactured in-house by a team of specialists with expertise in the loading bay equipment industry. Stertil Dock Products is represented internationally by local sales organisations, exclusive distributors and a network of qualified Stertil Dock Products Service partners. Stertil Dock Products is the No. 1 safety and quality specialist in loading bay dock equipment and especially in automated vehicle restraints.

This and a whole array of other patented products is a result of more than 45 years of experience and a continued commitment to ensuring safety in and around the loading bay.

SAFETY, FLEXIBILITY AND EFFICIENCY

The COMBILOK® G² vehicle restraint is a spearhead for safety and accident prevention. Unique in the market, the G² can restrain a diverse fleet of vehicles.

Vehicles of various models, axle configurations and with different sized wheels.

This compactly designed new generation automatic vehicle restraint, allows for extra shunting space and vehicle manoeuvrability at the loading bay. It is suitable for both existing and new distribution centres and warehouse facilities.



➤ THE NEXT GENERATION



➤ **COMBILOK® G²**



The COMBILOK® G² offers maximum safety, has been engineered for optimum durability, has a long lifespan and is accredited by TÜV according to the EC Machinery Directive 2006/42/EC.

The Stertil Dock Products COMBILOK® G² is standardly supplied with a contra wheel guide. This wheel guide helps the driver position the vehicle more safely and accurately to the loading bay dock.

Designed and manufactured in the modern flow process production facility in The Netherlands, the COMBILOK® G² is truly a new generation of automated vehicle restraints. The G² is very compact and space-saving, is easy to install and due to the very reliable Stertil® Hydraulic system requires minimum maintenance. The "plug and play" installation of the COMBILOK® G² means that it is operational in a matter of hours and is suitable for all types of loading bays and with various fleets of vehicles.

- Maximum safety.
- Flexible versatility; broad range of vehicles types, wheel sizes and axles.
- Space-saving design, for more shunting area and vehicle manoeuvrability.
- Extremely durable galvanised sturdy construction and integrated wheel guide.
- Reliable Stertil® hydraulic system.
- Audio & visual safety options.
- TÜV Rheinland Approved According to the EC Machinery Directive 2006/42/EC.

MAXIMUM SAFETY



Correct positioning of leveller in the vehicle.

Accident Prevention with the COMBILOK® G²

The COMBILOK® G² safely restrains any commercial vehicle preventing both premature departure of the vehicle from the loading bay dock as well as "vehicle creep". Premature departure can be caused by miscommunication between the vehicle driver and the warehouse personnel. "Vehicle creep" is caused by the abrupt breaking of the forklift truck in the parked vehicle. This creates a gap between the leveller and the vehicle floor. This gap is a potential hazard for both personnel and equipment, which may either get trapped or fall between the gap.



"Vehicle creep" risk without COMBILOK® G².

Most importantly, and it cannot be emphasised enough, the COMBILOK® G² prevents the vehicle driver from premature departure from the loading bay, an error easily made due to time pressure or miscommunication between the driver and warehouse personnel.



Premature departure risk without COMBILOK® G².

The G² also inherently works as a deterrent to potential theft by restraining the vehicle at the loading bay and hindering access to either the back of the vehicle or the opening of the building. If you want to keep your personnel and goods safe and secure a COMBILOK® G² is essential.



Safely and securely restrained with COMBILOK® G².

PREVENTING ACCIDENTS AND INCREASING PRODUCTIVITY



- All hydraulic components are protected inside the galvanized housing.
- Complete protection from external elements, such as damp and dirt.
- Compact design allowing an obstruction-free loading bay entrance.
- Integrated galvanized wheel guide.
- Audio and visual safety options.



WHITE SOUND



ADVANCED LED GUIDANCE SYSTEM
900 LUMENS-30-50,000 HOURS

Audio and Visual Safety Options

The additional audio and visual safety features of the patented Stertil Dock Products G² are very distinguishable.

The standard black and traffic yellow Stertil chevron striping on both the COMBILOK® G² and the contra wheel guide ensure constant visibility and attract attention.

A novel advanced guidance system is available with automated indirect energy-efficient LED lighting ensuring absolute visibility and safe guidance for the vehicle driver, especially when the light is poor, for example from dusk to dawn, or in unfavourable weather conditions. The activation of the G² is unmistakable with the optional alternating white and red LED lighting.

There is also a “white sound” option for suburban locations especially developed to reduce environmental impact caused by noise.

DURABLE AND RELIABLE

Robust

The robust galvanized G² is very sturdy and compactly designed. With very few moving mechanical parts, it is less susceptible to malfunction which reduces the risk of costly repair. The G² is weatherproof even in extreme conditions and is an incredibly good investment in terms of safety and reliability.

TÜV Rheinland Approved and CE Certified

The G² has been tested thoroughly in the field, is TÜV approved according to the EC Machinery Directive and is CE certified.



CERTIFIED

➤ FOR ALL SIZES AND TYPES OF COMMERCIAL VEHICLES

What immediately catches the eye, and what makes the COMBILOK® G² game-changing for the industry, is its flexible versatility. The G² is suitable for all vehicle sizes and models.

From small commercial vehicles to large articulated vehicles. For vehicles with or without side skirts; independent from the number of axles and whether the vehicle has rear steering axles. The G² can uniquely and effortlessly restrain all.





➤ FLEXIBLE VERSATILITY

460 mm

240 mm

PROGRAMMABLE LOCKING HEIGHT RANGE FROM A MERE 240 MM TO 460 MM

The COMBILOK® G² facilitates a programmable locking height range from a mere 240 mm to an incredible 460 mm, thus ultimate flexibility to match any fleet requirements. Be it small wheel diametres, large wheel diametres, vehicles with or without skirts and even vehicles with multiple axles. Complete versatility on a day to day basis for all vehicles types and models.

Damage Prevention

The COMBILOK® G² is designed so that the blocking arm makes a sideways movement away from the vehicle when in operation. There is no contact with the vehicle or anything else, such as, mud-guards, lights, wheel rims, side skirts or the under-run protection.

Total versatility for all types of commercial vehicles:

- Small and large wheel diametres.
- Single and multiple axles.
- With and without skirts.
- Vehicles with under-run protection.



Large wheel diameter, double back axle and "side under-run protection".



Small wheel diameter and single back axle.

THE MOST SPACE-SAVING AUTOMATED VEHICLE RESTRAINT SYSTEM

The COMBILOK® G² measures **4.8 metres** in length and only requires approximately **6.3 metres** installation space. It is one of the most space-saving automated vehicle restraint systems on the market.

Due to its efficient design, the COMBILOK® G² allows for an unobstructed and smooth approach to the loading bay.

There are no extra hurdles or bumps like with conventional vehicle restraint systems which often have components mounted on the loading bay drive-way.

This smooth and uninterrupted approach for the vehicle driver makes it safer and easier to reverse onto the loading bay. Vehicle doors can also be opened beforehand, without the risk of goods falling out and getting damaged. Altogether, the G² allows for safe efficient loading and unloading.

Effective Compact Design

Due to its smart and compact design, the Stertil COMBILOK® G² is incredibly space-saving. Unlike other automatic systems on the market, it is so compactly designed that it does not impinge on your shunting space. SPACE IS VALUABLE at the loading bay. This makes the G² ideal for both new and existing building situations.

- Space-saving compact design.
- Prevents open-door docking damage.
- Restrains a wide range of vehicles.
- Suitable for new and existing buildings.
- Minimum maintenance.

4.8 metres in length



only 6.3 metres installation space required



Trailers with side skirts and low clearance.



Multiple axle and rear-steering axles trailers.

Synchronised safety control both
inside and outside of the building.
A complete safety circuit.



THE G² DUAL HEIGHT RESTRAINING CONTROL

The operation of the COMBILOK® G² is just as well thought out as the G² itself. The G² can be supplied with the Stertil® Key Dual Height Control option, which has been especially designed for safe intuitive use. Controlled with a key switch for trained authorised loading bay personnel. You can choose and adapt the restraining height according to your vehicle requirements.

This control option allows the use of two programmable blocking heights for a diverse fleet of vehicles. For the absolute premium in safety control there is also the option to choose the Stertil Dock Products G² two-way interlocking sequence.



The COMBILOK® G² control panel indicator light turns green and signals that the vehicle is safely restrained by the G². The leveller control panel indicator light also turns green indicating that the leveller is in position and loading or unloading can safely commence.

- Maximum safety.
- Flexible versatility; broad range of vehicles types, wheel sizes and axles.
- Space-saving design, for more shunting area and vehicle manoeuvrability.
- Extremely durable galvanised sturdy construction and integrated wheel guide.
- Audio and visual safety options.
- Reliable Stertil® hydraulic system.
- TÜV Rheinland Approved According to the EC Machinery Directive 2006/42/EC.

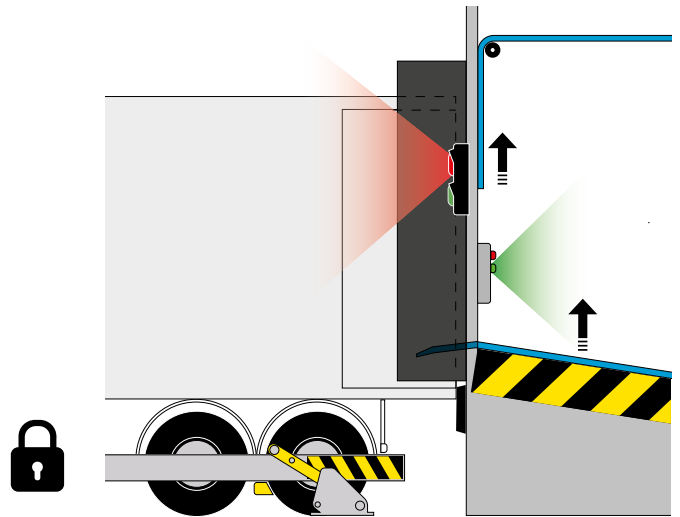

Part 1 of the Interlocking Sequence: Once the vehicle is restrained the traffic light turns red on the outside of the building indicating that the vehicle has been secured. At the same time on the inside of the building the COMBILOK® G² control panel indicator light turns green and signals that the vehicle is safely blocked by the G². **Only then, can the warehouse door be opened and the leveller operated.**

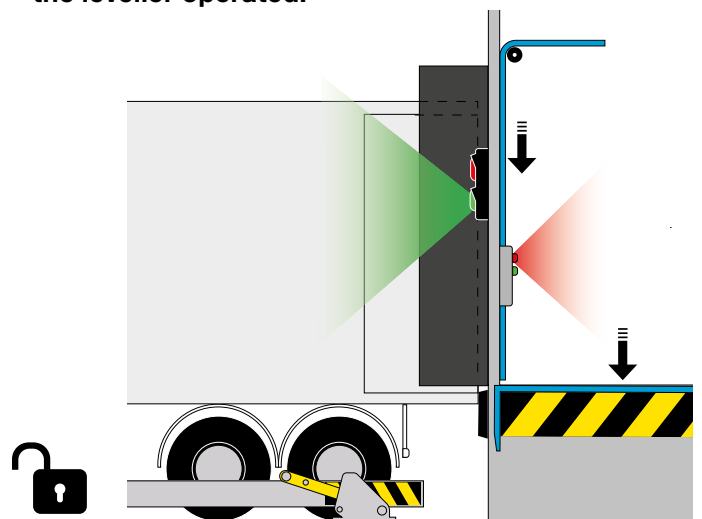

Part 2 of the Interlocking Sequence: Put the leveller in the "parked" position. The trailer doors are closed and the COMBILOK® G² releases the vehicle. The indicator light of the control panel on the inside of the building turns red and the traffic light on the outside of the building turns green. **The warehouse doors close.**

GAME-CHANGING AUTOMATIC VEHICLE RESTRAINT - THE G²

Stertil Dock Products continues to commit and deliver safe loading bay equipment solutions to logistics, warehousing & distribution centres. The G² brings a whole new level of safety to your loading bay.

TECHNICAL SPECIFICATIONS

- Length of COMBILOK® G² 4.8 metres
- Installation Space Required 6.3 metres
- Restraining Height Range from 240 mm - 460 mm
- Completely Electrical Hydraulically Operated
- Hydraulics Capacity 140 bar
- Electrical Capacity 0.75 kW
- Blocking Pressure 150 kN
- Length of Blocking Arm 350 mm
- Travel Range of the Blocking Arm 3,200 mm
- Control Voltage 24 V
- Mains Connection 3 x 400 V, 50 Hz, 1 x EARTH
- Manufactured from Galvanised Steel
- Integrated Galvanised Steel Wheel Guide
- Emergency Release Possible At All Times
- Delivery-Ready "Plug & Play" Installation
- TÜV Rheinland Approved According to the EC Machinery Directive 2006/42/EC

Please refer to the Installation and or Operations Manuals for detailed information and specifications.

This product and all other STERTIL® products are protected by patents from various regions and countries.

For more information please refer to: www.stertil.com/en/patents/. All rights reserved.

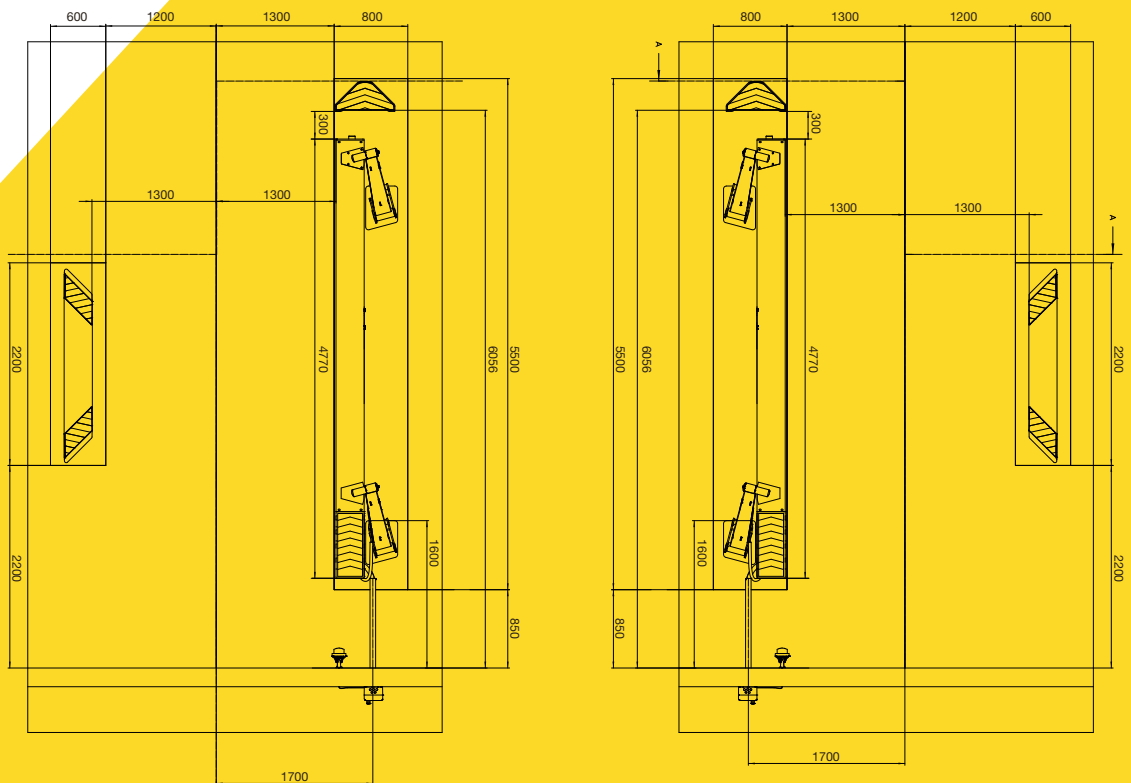

Options

- LED Lighting
- White Sound
- Stertil® Key Dual Height Control

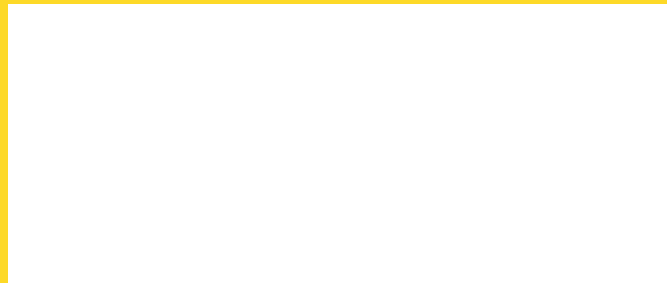

Further information

For more specific information or advice about the Stertil COMBILOK® G² and Dual Height Control or any of the other quality products manufactured by Stertil Dock Products, please contact us.

Watch the
COMBILOK® G²
Film:



Stertil B.V.
P.O. Box 23
9288 ZG Kootstertille
The Netherlands
Tel. +31 (0)512 334444
www.stertil-dockproducts.com
dp@stertil.nl
[/Stertil-b-v](https://www.facebook.com/Stertil-b-v)
Stertil Dock Products
@Stertil
Sterildock

 a member of the Stertil Group