

# The Dynaco D-311 door for food applications

The new generation high speed doors

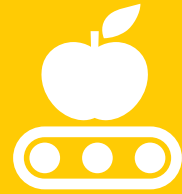

Your best asset  
to preserve  
perfect quality



- A smooth curtain and even-textured structure, respecting strict hygiene requirements.
- An extremely short cycle time protecting environments with temperature control.
- A perfect seal over the full perimeter of the door, resulting in significant energy savings.

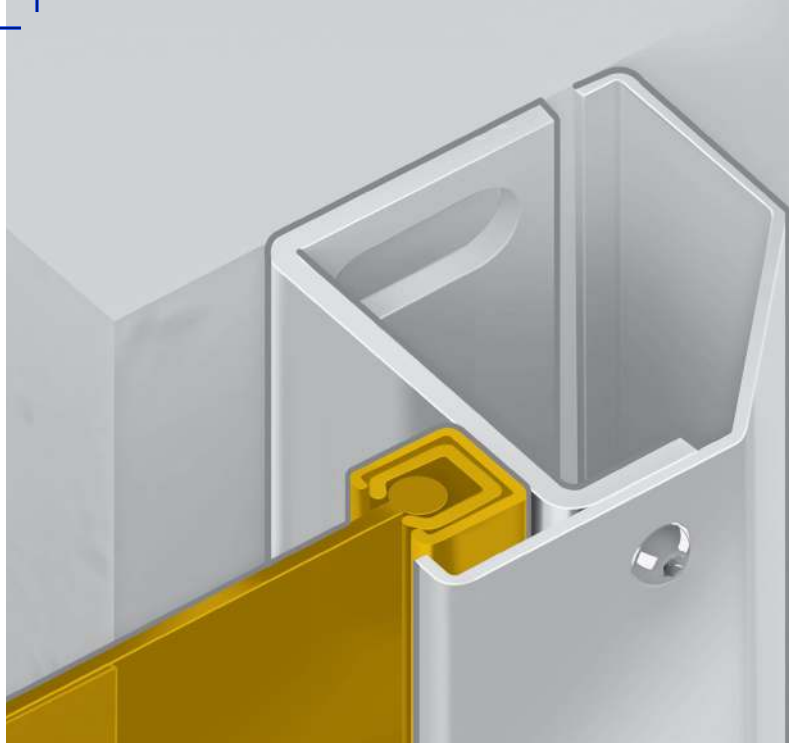

## EASY CLEANING

The surface of the Dynaco door curtain is smooth and even-textured. It is free of bars and other parts that could attract impurities. Add an optional stainless steel structure, and cleaning a Dynaco door becomes really easy.



## ENERGY SAVING

One of the main reasons for installing a Dynaco door, is saving energy. The fast operation of the doors and the tightness of the seal help prevent warm air entering the cooled areas or leaving the heated areas. This results in significant savings on your energy costs.



## PERFECT SEAL

In food processing environments, it is important to keep out dust, dirt and vermin. The tight seal and high speed of the Dynaco door avoids all kinds of contamination.



## STABLE TEMPERATURES

Dynaco doors not only open fast, but close fast as well. The time the door remains open is limited to a minimum. This avoids temperature inconsistencies which could impact product quality.



## SAFETY

With a Dynaco door, your safety is assured. Not only by standard safety devices such as detectors that automatically open the door. Also the curtain itself is perfectly safe, as it is flexible and free of rigid parts. That way, you avoid accidents that could happen with other types of doors.



## PRODUCTION EFFICIENCY

In a food processing environment, saving time is crucial. Goods are perishable; often the cold chain has to be respected. With a Dynaco door, not only you optimize your production flow thanks to the high opening and closing speed. The self-repairing character and the limited maintenance requirements of the door assure an uninterrupted uptime for your operations.



ENTREMATIc BELGIUM NV  
Waverstraat 21  
B-9310 Moorsel-Aalst (Belgium)  
Tel. +32 53 72 98 98  
Fax. +32 53 72 98 50  
info.dynaco.eu@entrematic.com  
www.dynacodoor.com

### About Dynaco

Founded in 1987, the Dynaco brand has a strong heritage and a wealth of expertise in high performance doors. Dynaco is committed to achieving excellence in quality and performance through a certified and dedicated network of partners, providing outstanding service to customers all over Europe. For our valued customers in the rest of the world, we trust our USA division and our licensed partners in Russia, Japan, China, Vietnam and Brazil to deliver on our customer promises.

Dynaco is part of Entrematic—the home to some of the world's most innovative and leading brands within the entrance automation industry. The comprehensive range of product brands includes Ditec, Normstahl and em/Entrematic.