



# DYNACO S-539

## Cat.2 Atex

### Compact

**Push-Pull**  
gear driven technology



inside door

# DYNACO S-539 Cat.2 Atex Compact

The Dynaco S-539 Cat.2 Atex Compact is specifically designed for inside applications in explosion sensitive environments, category 2. Officially approved by Apragaz notified body for use in potentially explosive atmospheres.

All metal parts are stainless steel, non-metallic parts are composed of antistatic or electrical conductive materials, thus avoiding the build up of static electricity that could generate sparks.

Operating speed and perfect sealing properties improve your traffic flows and provide employee comfort, environmental control and savings on energy costs.

Fully self-reinserting, the Dynaco S-539 Atex Cat.2 Compact will automatically reinsert itself in its side guides when the curtain is accidentally hit.

- **HIGH SPEED OPERATION:**  
Maximum speed 1 m/s.
- **PATENTED "PUSH PULL" TECHNOLOGY:**  
Unique door drive system.
- **CRASH FORGIVING AND SELF-REINSERTING WITHOUT INTERVENTION:**  
The curtain automatically reinserts itself when dislodged. No repair costs, no production downtime.
- **USER SAFETY:**  
Flexible curtain without rigid elements.
- **ADVANCED DRIVE:**  
Frequency driven motor and encoder for smooth operation. Wearable elements are reduced to a minimum.
- **DYNALOGIC CONTROL BOX:**  
User-friendly control box with self-diagnosis.
- **CONFORM TO EN13241-1**
- **CONFORM TO DIRECTIVE 2014/34/EU**  
Ex II 2 G/D  
Ex h T4 135°C  
Ex db ia e IIC T4 EPL Gb  
Ex tb ia IIIB 135°C EPL Db  
CE 0029 APRAGAZ 17 ATEX 0157 X  
T ambient -10°C to 55°C



All synthetic parts in antistatic material



Complete structure in stainless steel

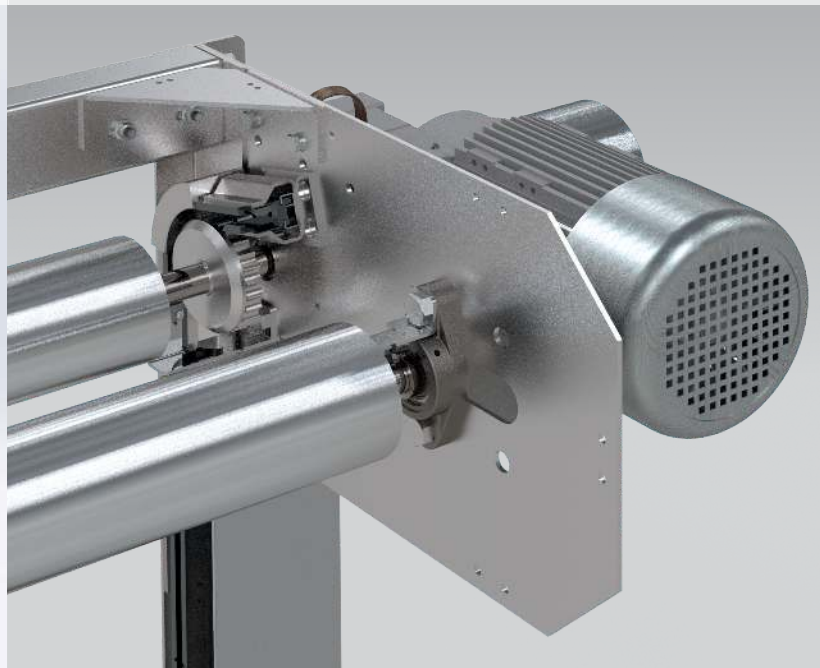

# Push-Pull

gear driven technology



inside door

## EN13241-1 STANDARDS

Standard	Ref.	Test acc.	Results
Water permeability	EN 12425	EN 12489	Class 1
Wind load	EN 12424	EN 12444	Class 1
Wind permeability	EN 12426	EN 12427	Class 1*
Safe openings	EN 12453	EN 12445	Pass
Mechanical resistance	EN 12604	EN 12605	Pass
Unintended movements	EN 12604	EN 12605	Pass
Thermal transmittance	EN 12428	EN 12428	6,02 W/m <sup>2</sup> K
Performance (cycles)	EN 12604	EN 12605	NPD

\* Valid for a door of 3500 x 3500mm

Explosion groups	Temperature class					
	T1	T2	T3	T4	T5	T6
Min. ignition temp. or max. surface temp.	450 °C	300 °C	200 °C	135 °C	100 °C	85 °C
I (Mining)	Methane					
IIA	Acetone Ammonia Benzene Acetic acid Ethane Ethyl acet. Methane Methanol Naphthalene Phenol Propane	i-Amylac- etate n-Butane n-Butane alcohol	Benzines Diesel fuels Fuel oils n-Hexane	Acetaldehyde		
IIB	Town gas	Ethylene Ethylene oxide	Hydrogen sulphide	Ethyl ether		
IIC	Hydrogen					Carbon disul- phide

## CHARACTERISTICS

<b>Max. dimensions</b>	W 5.500 mm x H 5.500 mm
<b>Opening speed</b> <b>Closing speed</b>	Maximum 1 m/s 1 m/s
<b>Structure</b>	Stainless steel: 80 x 40 x 3 mm.
<b>Drum</b>	Stainless steel - Ø 102 x 1.2 mm.
<b>Side guides</b>	Reinforced antistatic polyethylene (PE-UHMW1000 carbon black) on springs.
<b>Motor</b>	4 poles, without brake. Ex d Power 1,5 kW - IP rating: IP 66
<b>Control box</b>	DYNALOGIC 5 (500x500x250mm) provided with: circuit breaker, general divider, adjustable timer, push button for opening and reset, emergency stop and Ex i switching amplifier. IP rating: IP 65. Frequency inverter. Always to be installed outside the danger zone.
<b>Standard detectors</b>	Ex ia infrared barrier: 300 mm from the floor. Bottom edge detection via intrinsic safety barrier
<b>Power supply</b> <b>Frequency</b>	Single phase 230V - 16 A Frequency: 50-60 Hz
<b>Available colours</b> comparable with:	Black RAL9005  (Actual colour may deviate. Colour sample availa- ble upon request)

Atex motor, gearbox and encoder



Bottom edge detection via intrinsic safety barrier



Standard earthing kit



## Dimensions and installation requirements Dynaco S-539 Cat.2 Atex Compact

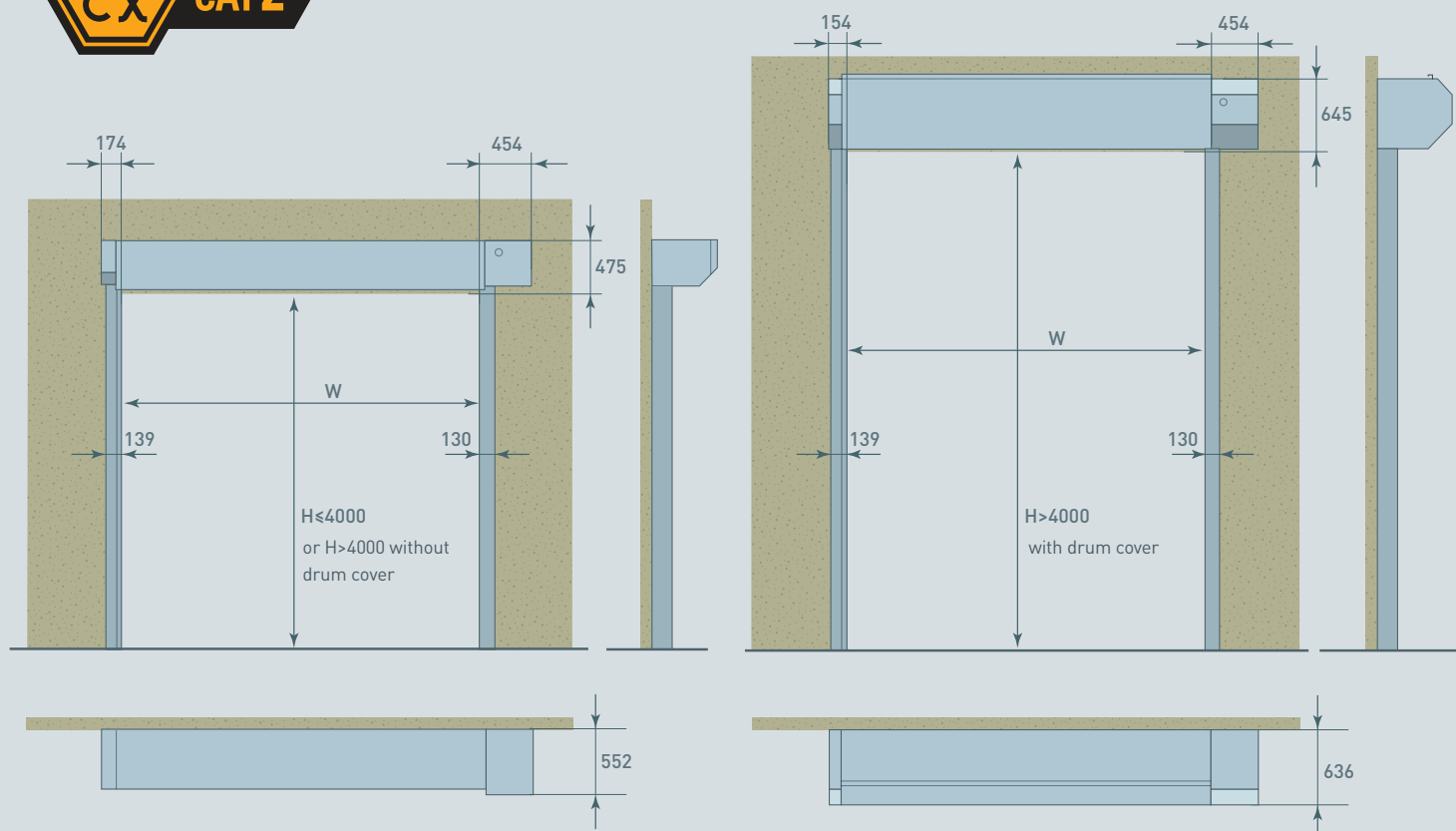

All indicated dimensions are net: the space necessary for mounting and maintenance has to be provided. Reduced dimensions: upon request.

REMARK: Based on the risk analysis of the environment, extra push buttons, detectors and covers might be required.



ENTREMATIc BELGIUM NV  
 Waverstraat 21  
 B-9310 Moorsel-Aalst (Belgium)  
 Tel. +32 53 72 98 98  
 Fax. +32 53 72 98 50  
 info.dynaco.eu@entrematic.com  
 www.dynacodoor.com

### About Dynaco

Founded in 1987, the Dynaco brand has a strong heritage and a wealth of expertise in high performance doors. Dynaco is committed to achieving excellence in quality and performance through a certified and dedicated network of partners, providing outstanding service to customers worldwide. Furthermore we trust our USA division and our licensed partners in Russia, Japan, China, Vietnam and Brazil to deliver on our customer promises.

Dynaco is part of Entrematic—the home to some of the world's most innovative and leading brands within the entrance automation industry. The comprehensive range of product brands includes Ditec, Normstahl and em/Entrematic.