

## The Dynaco S-5 Atex Cat.2 for explosion proof applications

The new generation high speed doors



Your best asset  
to reduce  
the risk  
of explosion



- Each door pre-assembled and individually Atex Cat.2 certified.
- Ideal solution to partition the workspace and separate Atex zones.
- Guarantees maximum safety and improves working conditions in Atex environments.

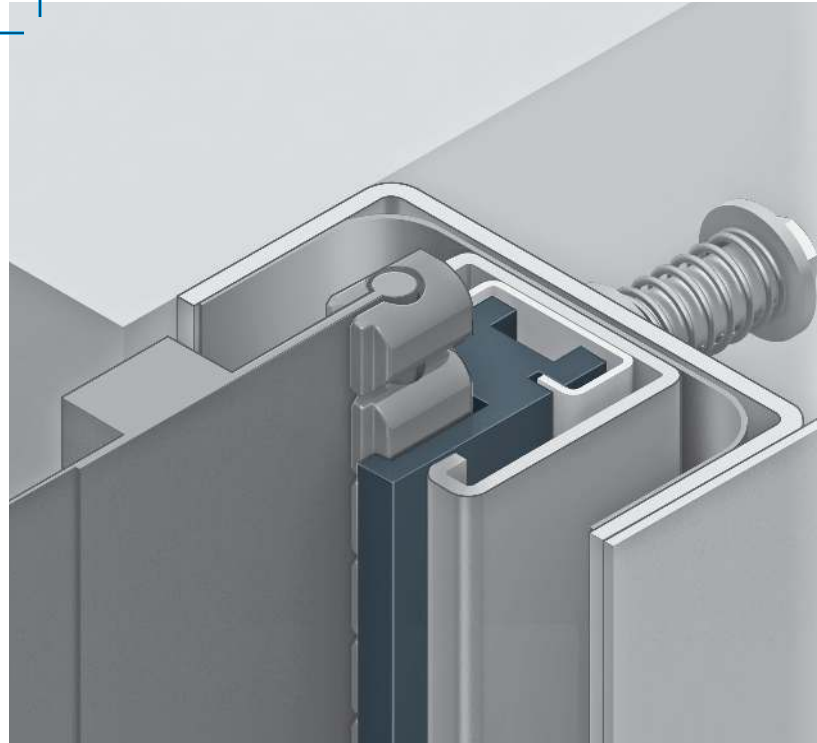

## SMOOTH OPERATION

The Dynaco S-5 Cat.2 Atex door is provided with an Atex Encoder, making opening and closing of the door curtain more smooth and reliable. The door stops exactly at the indicated positions, without the need of changing settings. There's no risk of the door curtain running beyond its limits. Thus, damage to the door and time-consuming interventions are avoided.



## ENERGY SAVING

One of the main reasons for installing a Dynaco door, is saving energy. The fast operation of the doors and the tightness of the seal help preserve the conditioned area. This results in significant savings on your energy costs.



## SAFETY

All Dynaco doors are intrinsically safe for the users, thanks to the flexible door curtain. In explosive environments however, safety requirements are far more complex. With a Dynaco S-5 Cat.2 Atex door, nothing is left to chance. All metal parts are made of stainless steel, while all non-metallic parts with a surface larger than 20cm<sup>2</sup> are replaced by antistatic materials. Also, bottom edge detector and photocells are protected via an intrinsically safe barrier (Ex i). Thus, we can guarantee a Dynaco S-5 Cat.2 Atex door generates no sparks that could lead to explosions and is safe for people and goods.



## PEACE OF MIND

Stating that a door is explosion proof is one thing. A Dynaco S-5 Cat.2 Atex door however is pre-mounted and tested on our premises and individually certified by Apragaz, an accredited notified body for Atex regulations. Both the non-electrical equipment and the driving parts have been thoroughly reviewed and validated. Each door will be carefully inspected by Entrematic quality organization and the independent notified body, conformity to Atex regulations (according to the European directive 2014/34/EU) will be detailed in a Declaration of Conformity by the independent party. That way you can rest assured that the door is suitable for the indicated environment.



## UNINTERRUPTED WORKFLOW

When a Dynaco door is accidentally hit and dislodged from its side guides, it automatically reinserts itself after an opening cycle. No need for technical intervention. No down-time for your installations. A solution that is saving both time and energy!



## BETTER WORKING ENVIRONMENT

The Dynaco S-549 Cat.2 Atex Power version is suitable for outside applications. The specially designed side guides and the reinforcement at the bottom allow the door to operate under regular wind load. That way it protects your premises against bad weather and increases the comfort of your employees.



## OPERATIVE UNDER HARSH CONDITIONS

The Dynaco S-559 Cat.2 Atex All Weather version is ready to operate under heavy weather conditions. The flexible curtain bends under wind pressure, while a special reinforcement avoids the curtain being torn away from the side guides. That makes the Dynaco S-559 Cat.2 Atex All Weather door suitable for all kinds of heavy duty applications.



ENTREMATIC BELGIUM NV  
Waverstraat 21  
B-9310 Moorsel-Aalst (Belgium)  
Tel. +32 53 72 98 98  
Fax. +32 53 72 98 50  
info.dynaco.eu@entrematic.com  
www.dynacodoor.com

### About Dynaco

Founded in 1987, the Dynaco brand has a strong heritage and a wealth of expertise in high performance doors. Dynaco is committed to achieving excellence in quality and performance through a certified and dedicated network of partners, providing outstanding service to customers all over Europe. For our valued customers in the rest of the world, we trust our USA division and our licensed partners in Russia, Japan, China, Vietnam and Brazil to deliver on our customer promises.

Dynaco is part of Entrematic—the home to some of the world's most innovative and leading brands within the entrance automation industry. The comprehensive range of product brands includes Ditec, Normstahl and em/Entrematic.